

# 90020-05XXX X-600 X-300 AF-6318

First Design Date :2003/09/30

**Model : AF-1900CN djminato**

**Revision:4.2 Date : 2004/05/14**

연구소	추가 ARTWORK	CHECK1	CHECK2	CHECK3	CHECK4	APPROVAL
승 인						

**\* Revision:3.0A \***

1.AF-8110EC(V3.1)에서 TDA8004 및 SMART CARD 삽입 0194 TUNER 적용

**\* Revision:3.0B \***

2.1번항 삭제, 기존 SMART CARD 적용

**\* Revision:3.0C \***

3.R311 (RESET부위)부품 위치변경, VCXO 중간홀 삭제

**\* Revision:3.0D \***

4.1번항 재적용-TDA8004 MAIN BOARD 에 적용

5.LNB 단 삭제-R166,D152

추가-C154(0.1uF)/C153(47nF)/R167(240)/R168(68)

**\* Revision:3.3 \***

1.TURNER Location NO. 정정 U101->U102

2.SMART CARD INTERFACE PART 정리

**\* Revision:3.3A 040120\***

1.LNB관련 ECO적용 추가-D151(1N4004-SMD TYPE)

2.RS232 단 추가-B953(10uH), CE951(10uF/16V), 5V연결 변경

**\* Revision:4.1 040312\***

1.TUNER 단 추가-C104~105(100pF)

2.TUNER 단 변경-D151(1N4004 SMD TYPE => DIP TYPE)

3.POWER 단 변경-CN901 2,3(23V)번 연결, R902(10K)연결변경

4.AUDID 단 추가-DZ601(6.3V), CE613(470uF/10V)

**\* Revision:4.2 040513\***

1.SMART CARD 단 삭제-CB406~407(0.1uF) CN401 연결부분

2.SMART CARD 단 변경-CN401(MOLEX 2.5MM, 8P) NET 연결 변경

3.SMART CARD 단 추가-CB406 0.1uF VDD(3.3V) 적용

4.SMART CARD 단 변경-R401(기존R414에서 R401로 이름변경)

5.SMART CARD 단 추가-신규 SMART CARD BOARD 적용

6.SMART CARD 단 추가 C401~403 (220pF)

7.SMART CARD 단 삭제 - R413,R415~417,R419~420,R440 (33R) 삭제

8.SCART 단 변경 - R701,R720,R781 (33R) => 100R

9.TUNER 단 변경 - C154 (0.1uF -> 3.3nF), R167 (240R -> 20R)

10.POWER, MODULATOR 단 변경 - 30V 관련 부품 NC

11.OPTION -U601-1(CDB4344), C615(0.01uF), CB614(10uF/16V)



CPU : XX301 ~

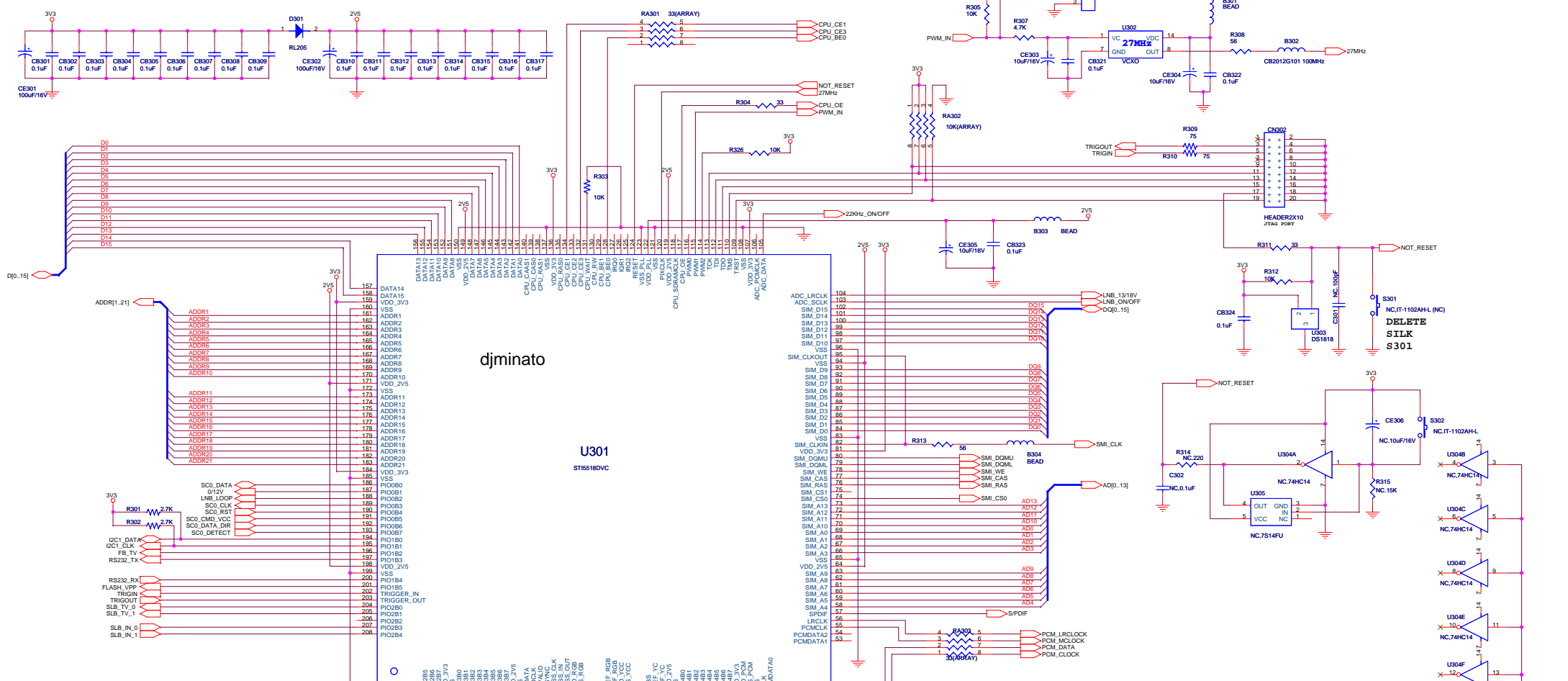

FRONT : XX351 ~

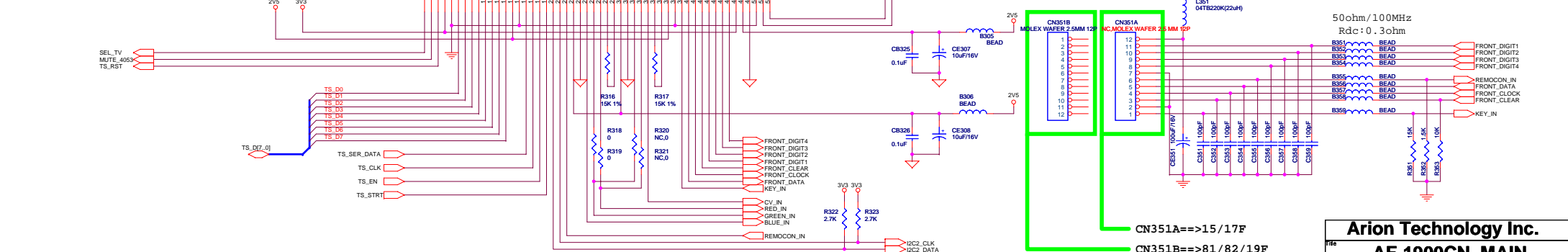

**Arion Technology Inc.**

Rev: 4.1

Document Number: **02-5518MAIN/Front**

Date: Tuesday, June 22, 2004 Sheet 2 of 6

SDRAM : XX371 ~

FLASH : XX381 ~

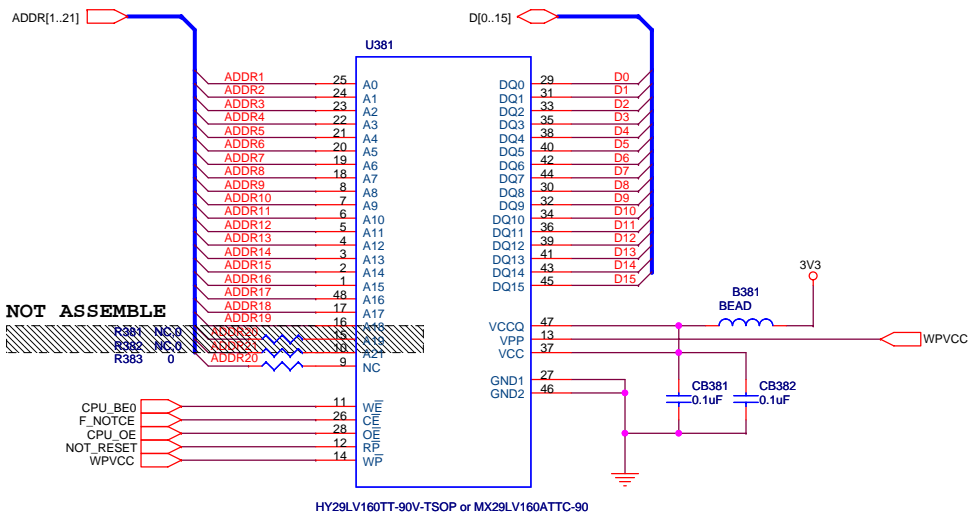
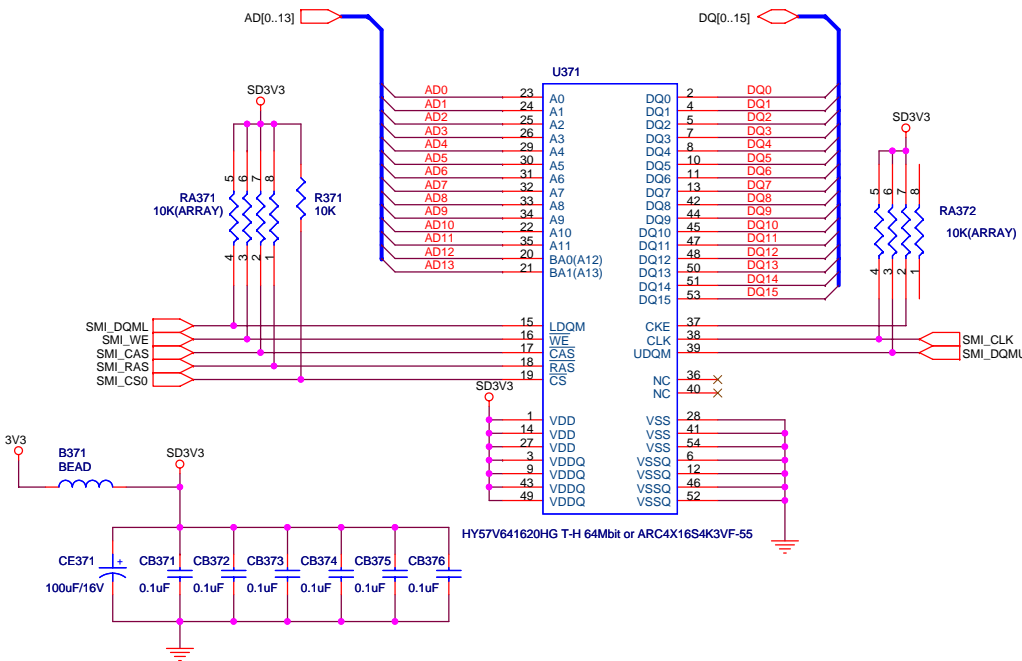

djminato

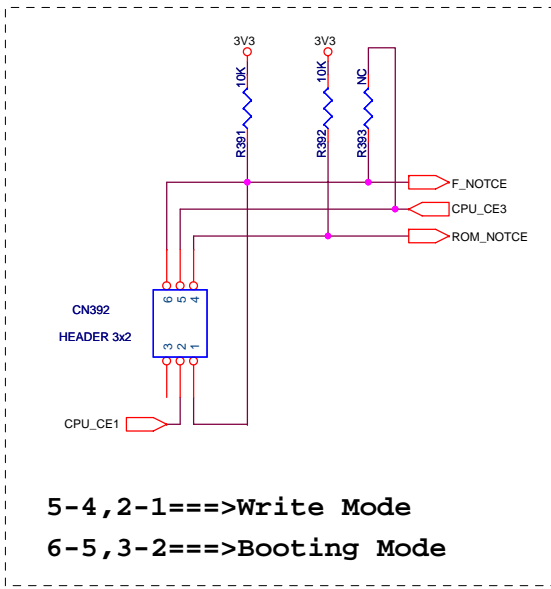

5-4,2-1==>Write Mode  
 6-5,3-2==>Booting Mode

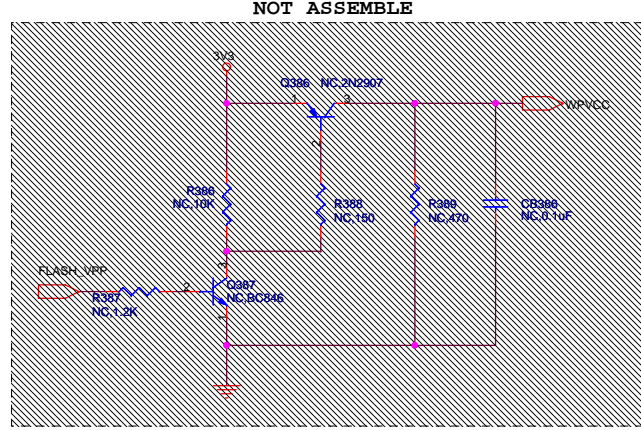
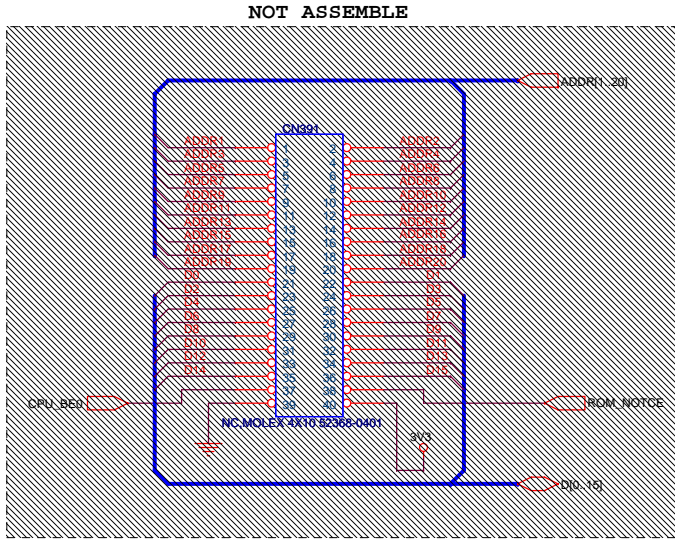

AUDIO : XX601 ~

SCART : ALL INSERT  
 S-VIDEO : RED, GREEN INSERT  
 FOR ARABIC : RED, GREEN, BLUE DELETE  
 FOR EUROPE : RED, GREEN, BLUE INSERT

RED : XX661 ~

GREEN : XX671 ~

BLUE : XX681 ~

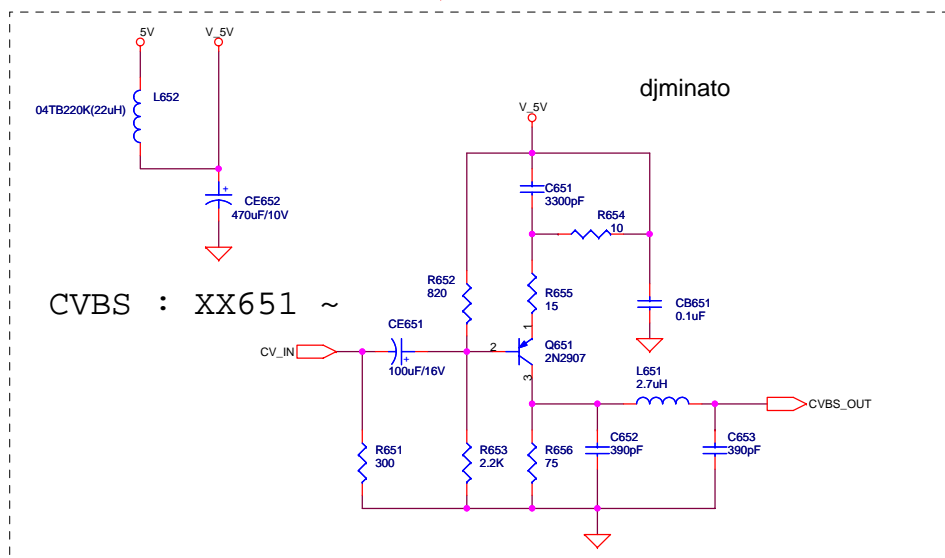
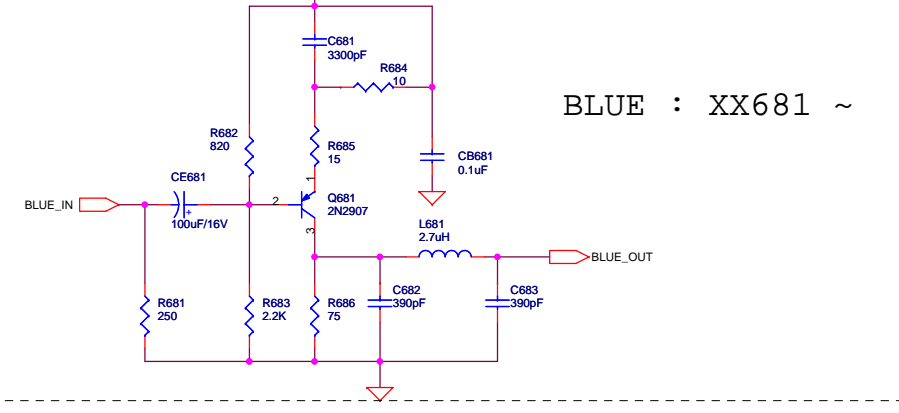
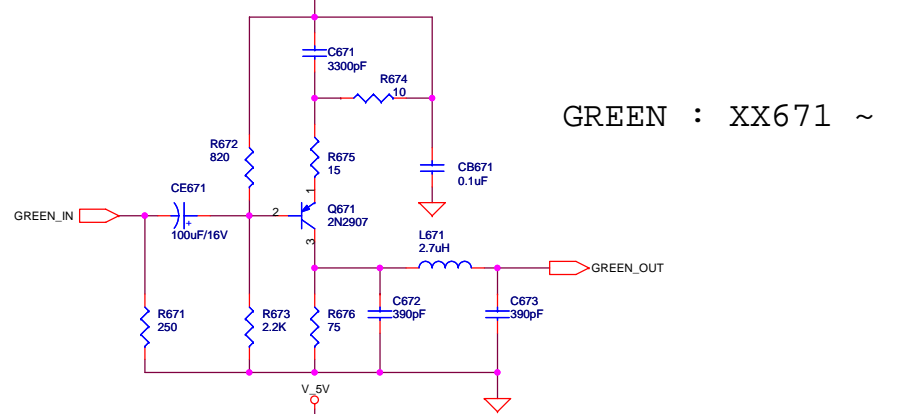
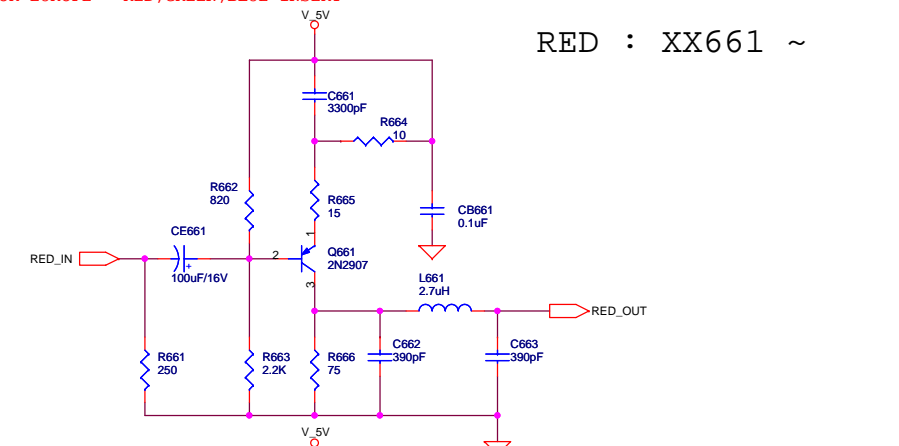
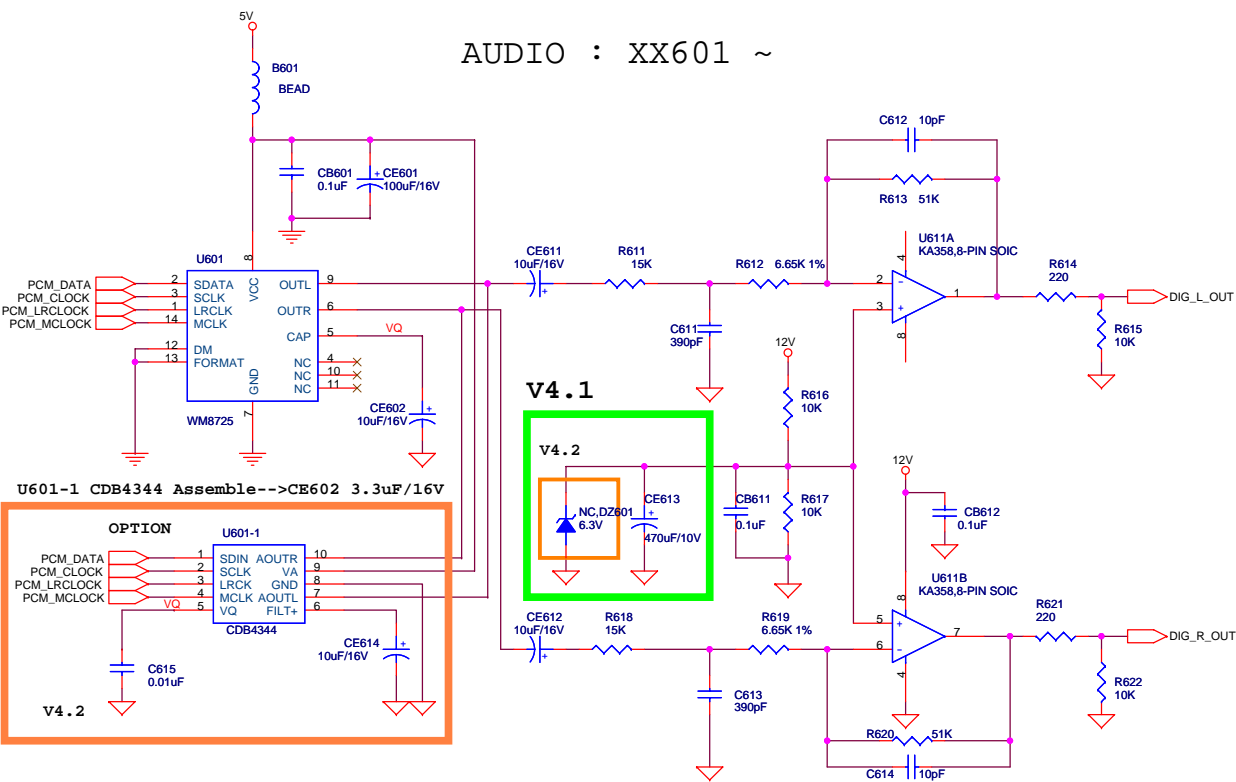

SCART : XX701 ~

TV/VCR SCART & RCA : NC(R704,705,706),OTHER INSERT  
 RCA ONLY : INSERT(R704,R705,R706,CE701,CE702,RA702),OTHER NC

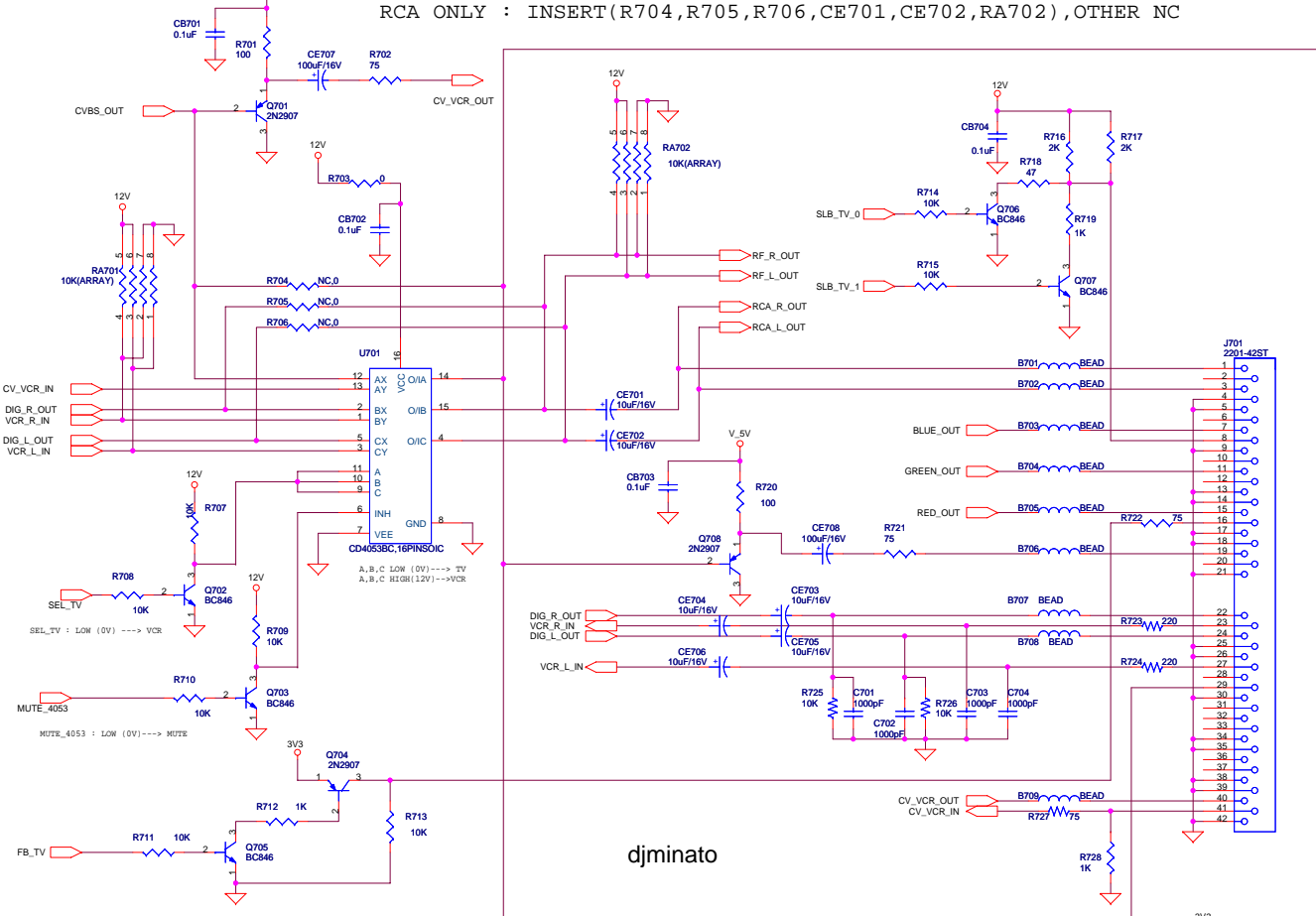

djminato

RF\_MOD : XX801 ~

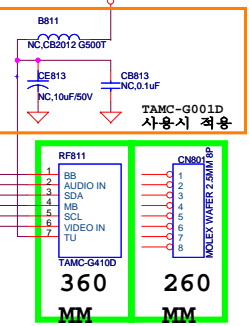
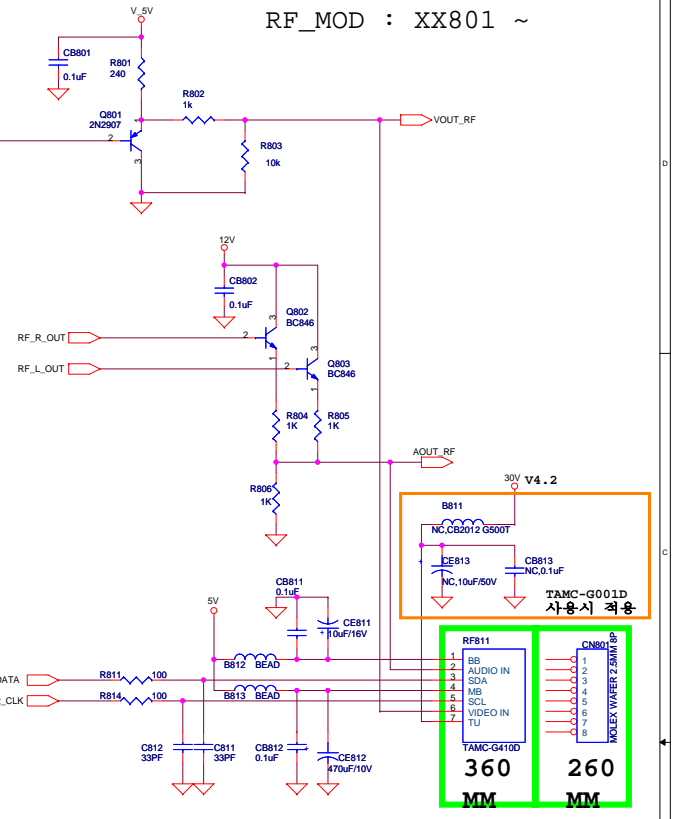

RCA : XX771 ~

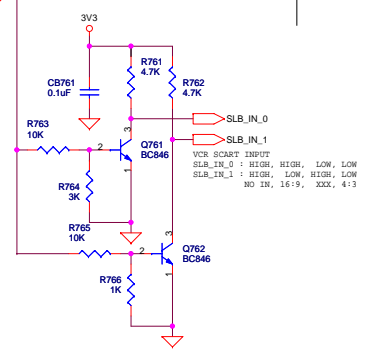
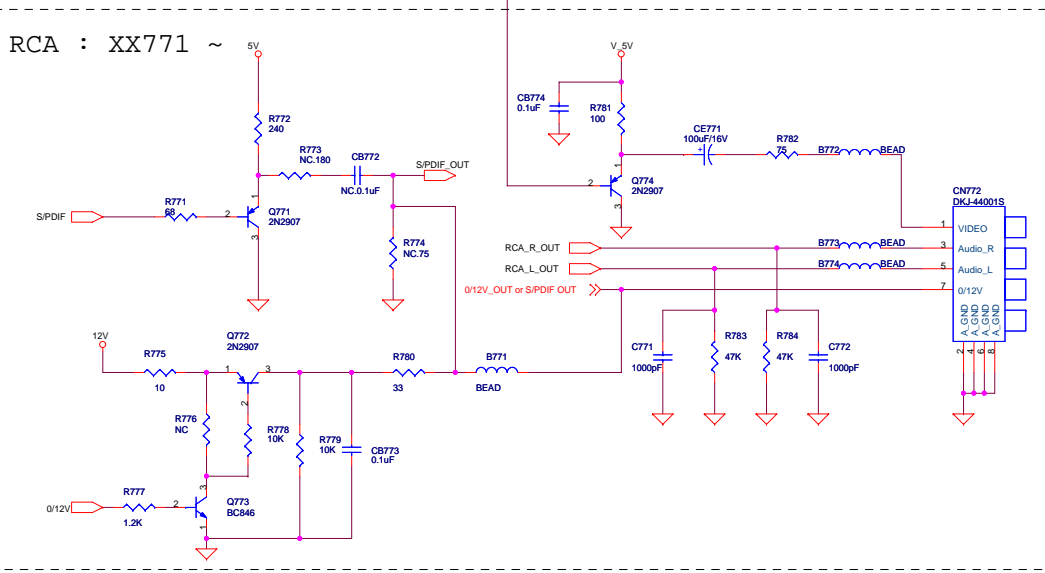

S-VIDEO : XX851 ~

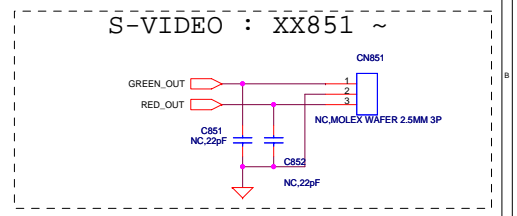

# SMART CARD : XX401~

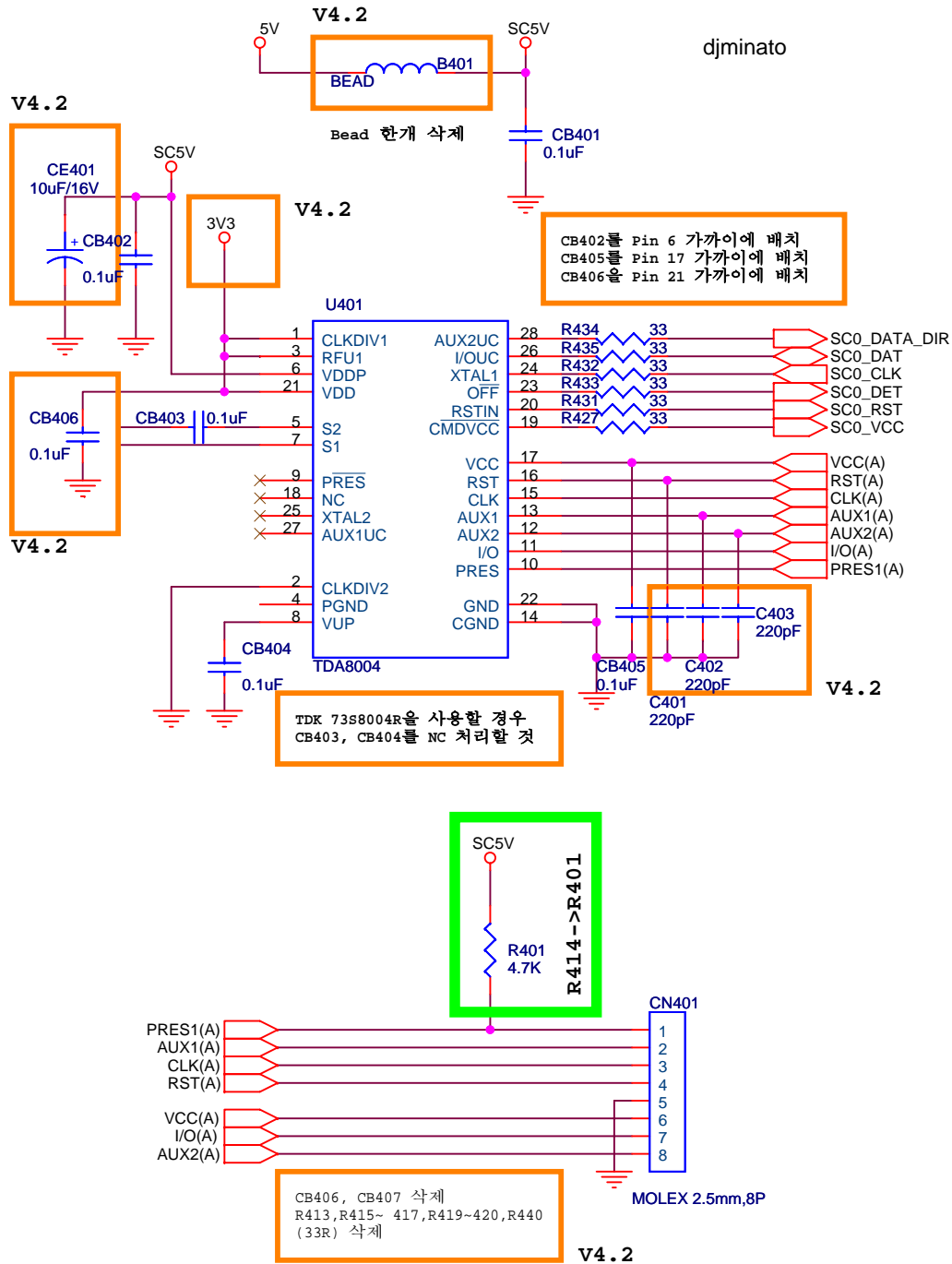

## V4.1

### SMARTCARD SUB B'D : XX451 ~

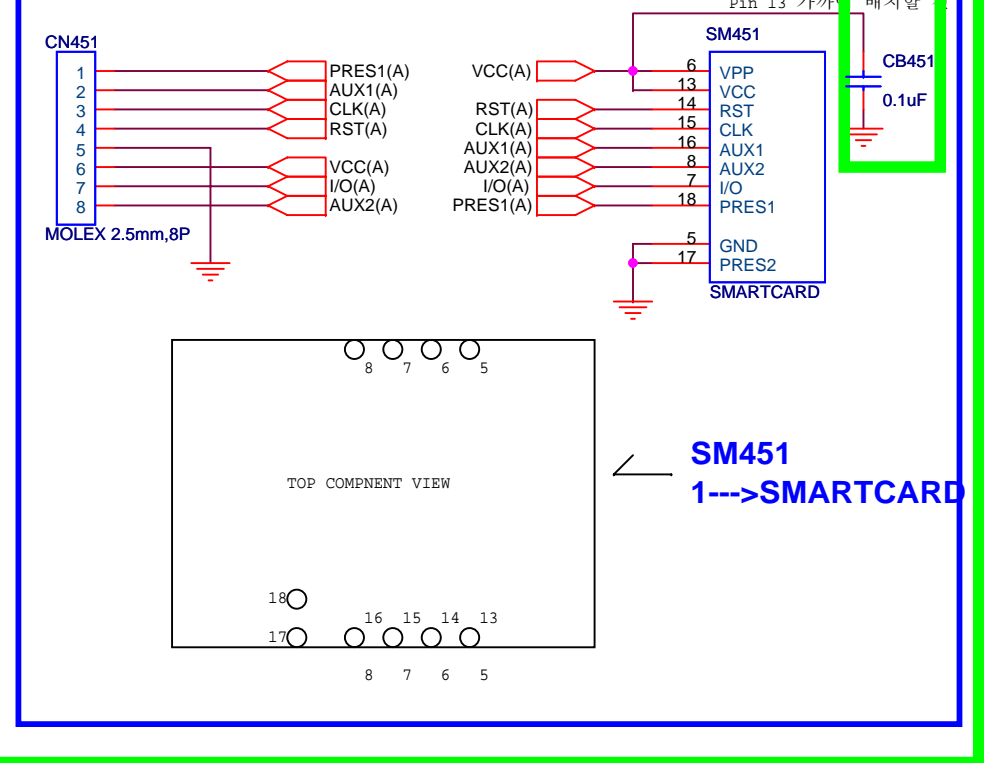

<b>Arion Technology Inc.</b>			
<b>AF-1900CN MAIN/SUB</b>			
Size A4	Document Number <b>06-TDA8004/SMART CARD</b>	Rev 4.1	
Date: Tuesday, June 22, 2004	Sheet 6	of 6	