

5 4 3 2 1  
**90020-02XXX**

First Design Date :2003/11/19

**Model : MF-26A1CI(AF-1900CI\_NEW)**

**Revision:4.2 Date : 2004/07/27**

연구소	ARTWORK	CHECK1	CHECK2	CHECK3	APPROVAL
승 인					

**\*Revision:4.0D\***

- 1)PCB PAD추가 - R109, 변경 R328->R734로 Location No.변경
- 2)STi5518 단 추가 - R331(10K) CIMAX\_RST 출력 Pull Up 저항 추가
- 3)SMART CARD 단 변경 - R403(0R)->B401(50ohm BEAD)
- 4)SMART CARD 단 변경 - CB406~407(0.1uF)->CB451~452 변경
- 5)SMART CARD 단 변경 - CB402,CB405~406,CB408,CB411~412 (0.1uF) 위치를 TDA8004 에가깝게 변경
- 6)SMART CARD 단 변경 - TDA8004의 CLKDIV1(1p),RFU1(3p),VDD(21p) 전원을 5V -> 3V3으로 변경
- 7)SMART CARD 단 추가 - C401~406(220pF)
- 8)SMART CARD 단 삭제 - RA401~403 (33R ARRAY),R404~405(33R)
- 9)CiMAX 단 추가 - R233~234 (56R),RA213(33R ARRAY)

**\*Revision:4.0E\_040604\***

- 1)부품명 변경회로대로(C154) 및 회로빠진부분 회로도에 추가(CE905,10uF/16V)
- 2)SMART CARD 부의 변경
- 3)PCMCIA 기구홀 SIZE 변경(3.2=>2.4)

**\*Revision:4.1PP\_040626\***

- 1) 회로추가-XX391 ~ 관련 회로추가

**\*Revision:4.2\_040723\***

- 1) 추가-CN801, R853, C207-210

**Arion Technology, Inc. A/V R&D Lab**

Te l: 031-421-2500  
Fax: 031-421-2510

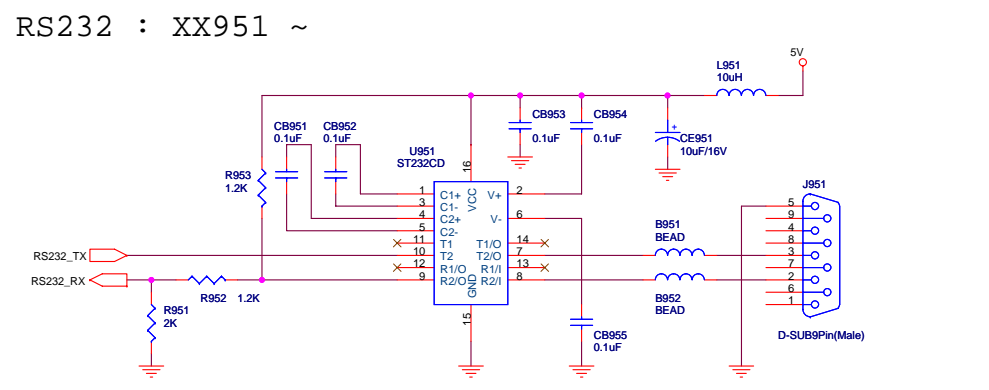
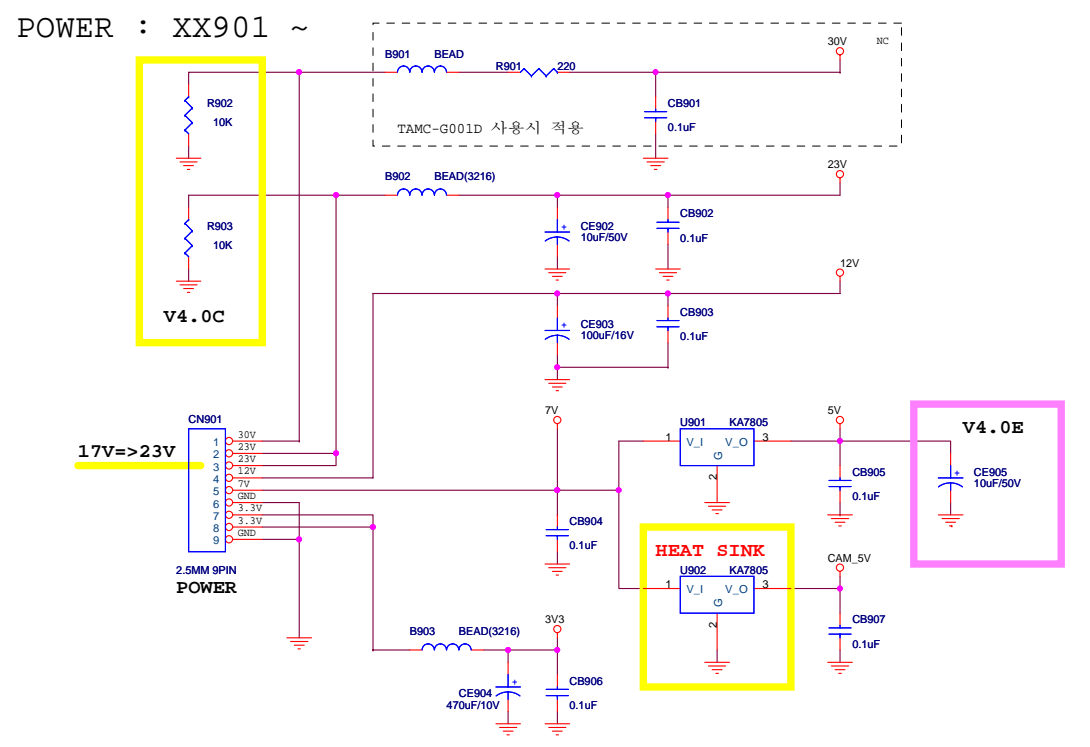
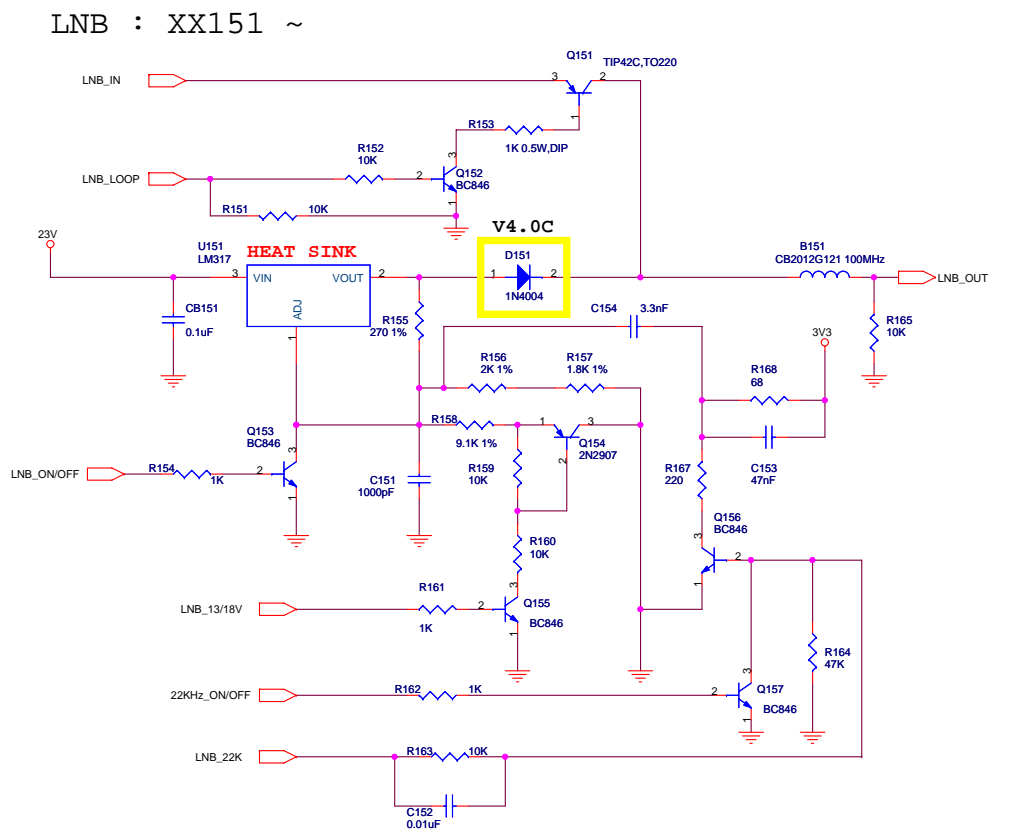
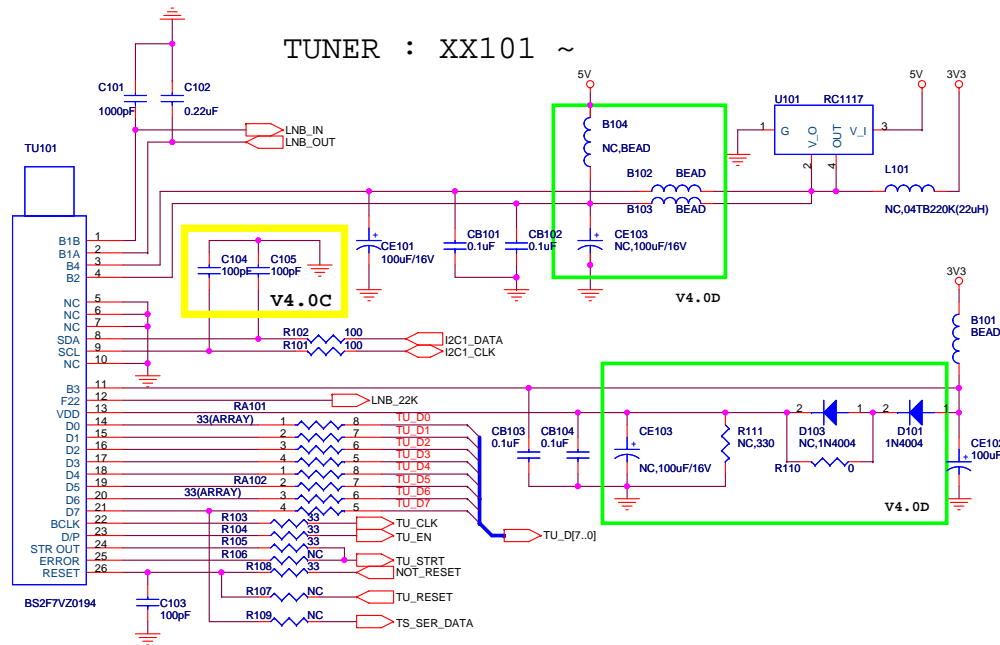

<b>Arion Technology Inc.</b>		
<b>AF-1900CI_NEW</b>		
Size	Document Number	Rev
Custom	<b>01-TUNER &amp; POWER&amp;LNB&amp;RS232</b>	4.2
Date:	Tuesday, July 27, 2004	Sheet 1 of 6

CIMAX & CAM : XX201 ~

2-3 : ST0700TYPE

V4.0D

VCC\_TSI(64p) 3V3  
으로 전원분리

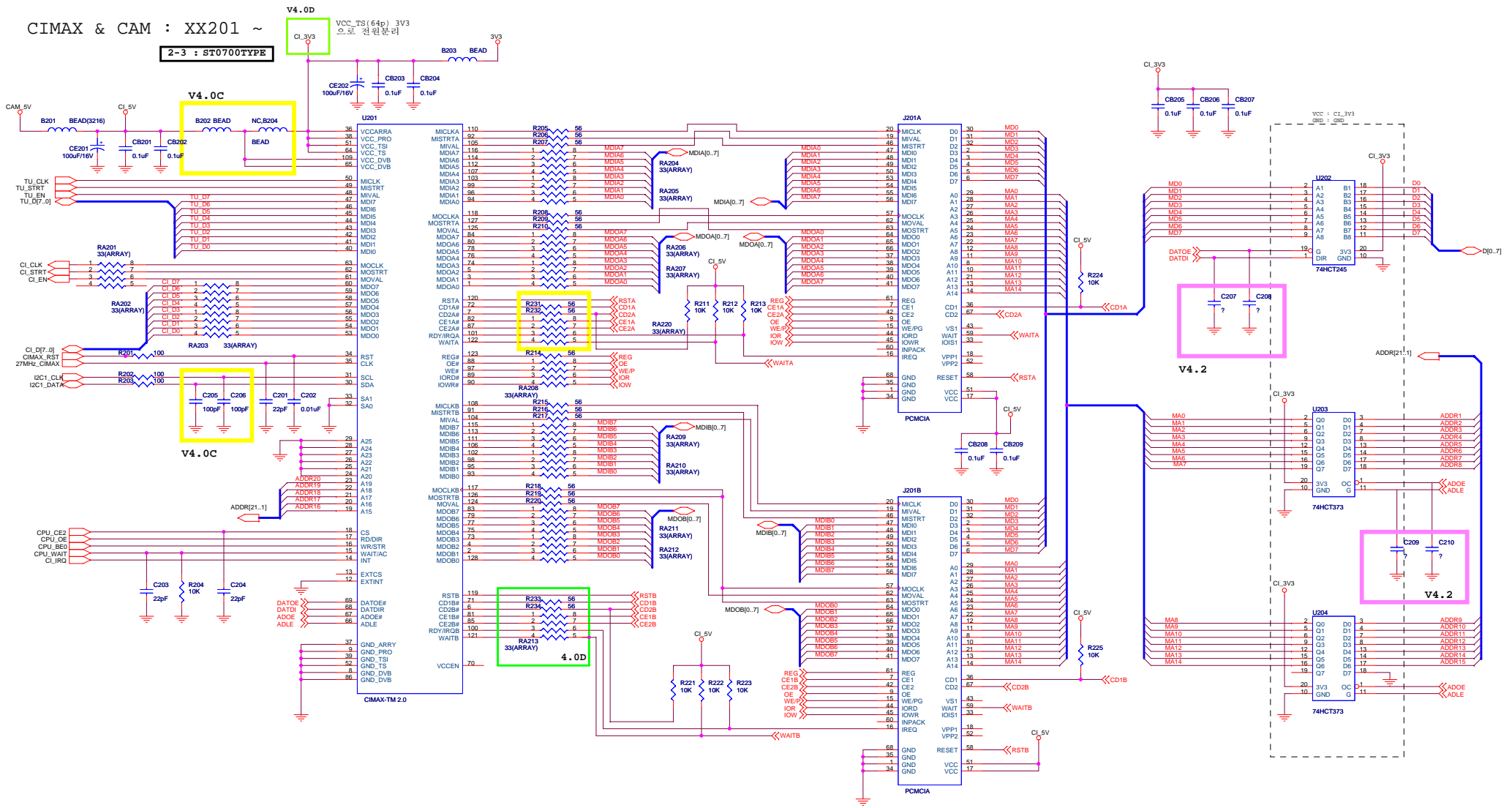

CPU : XX301 ~

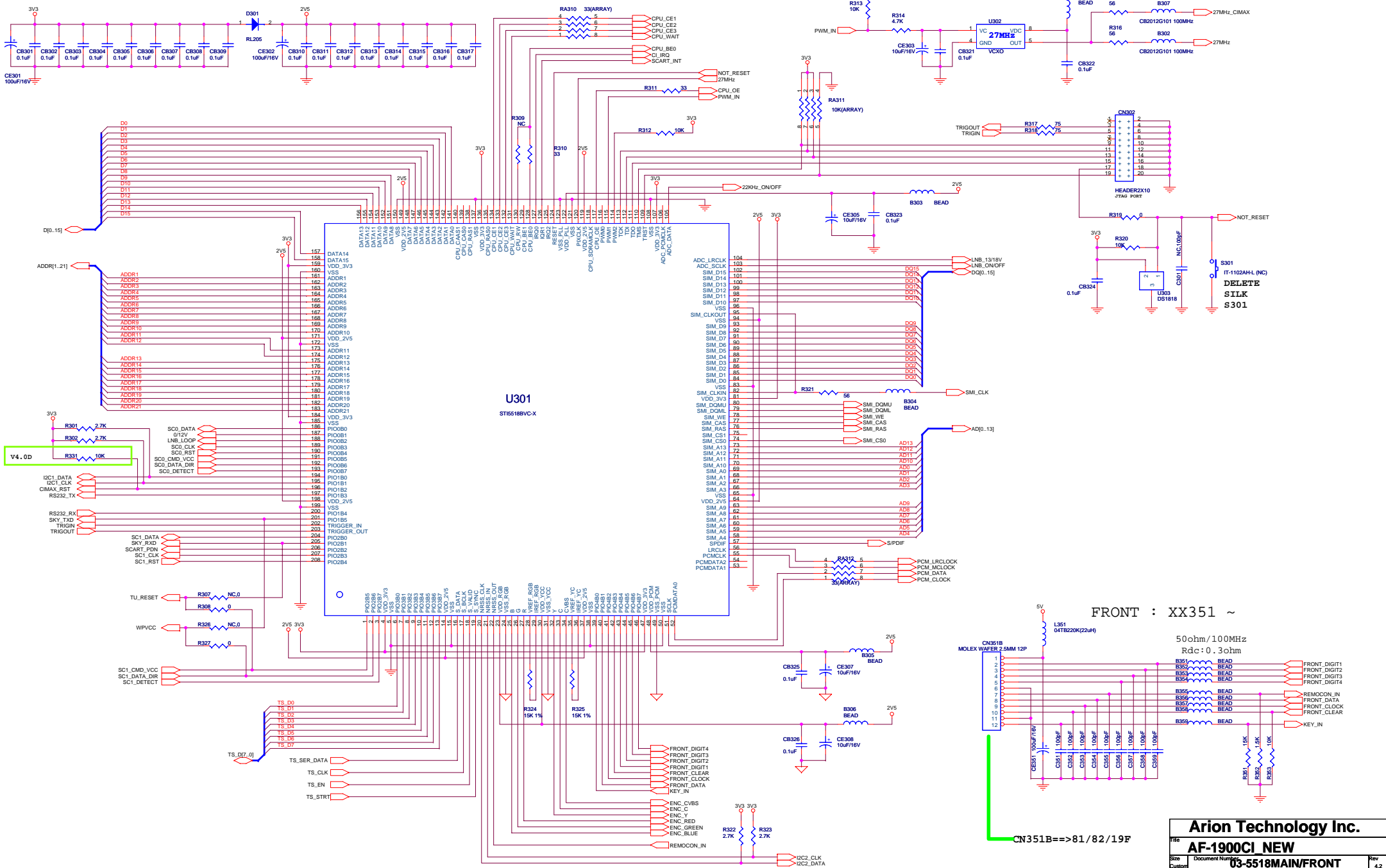

FRONT : XX351 ~

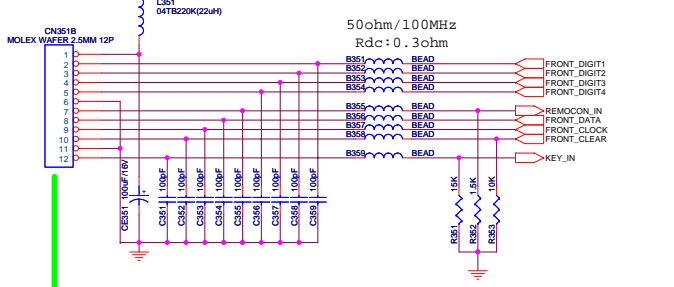

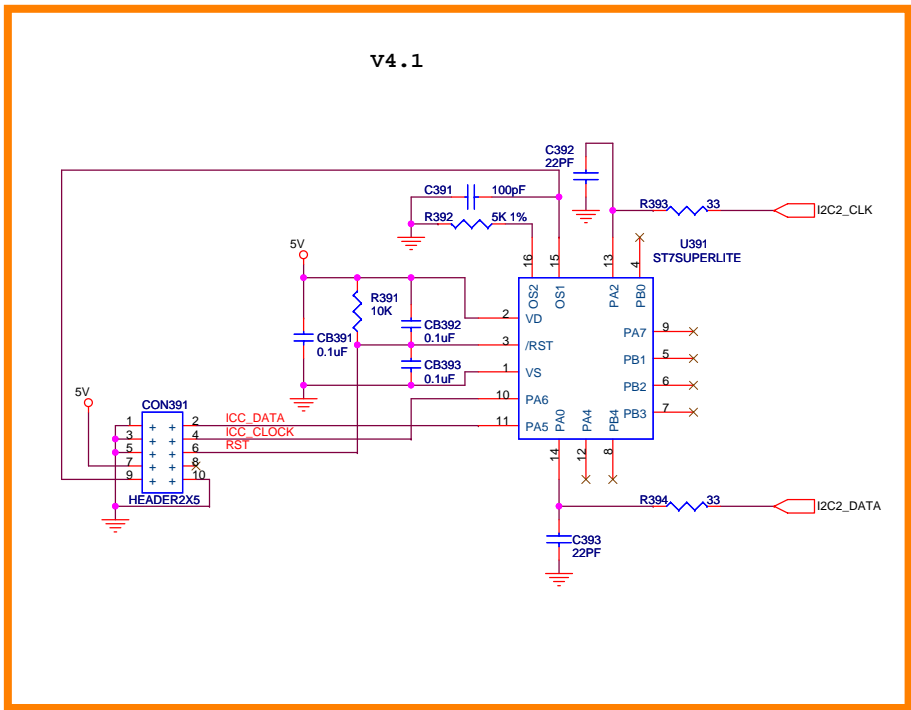

## FLASH : XX381 ~

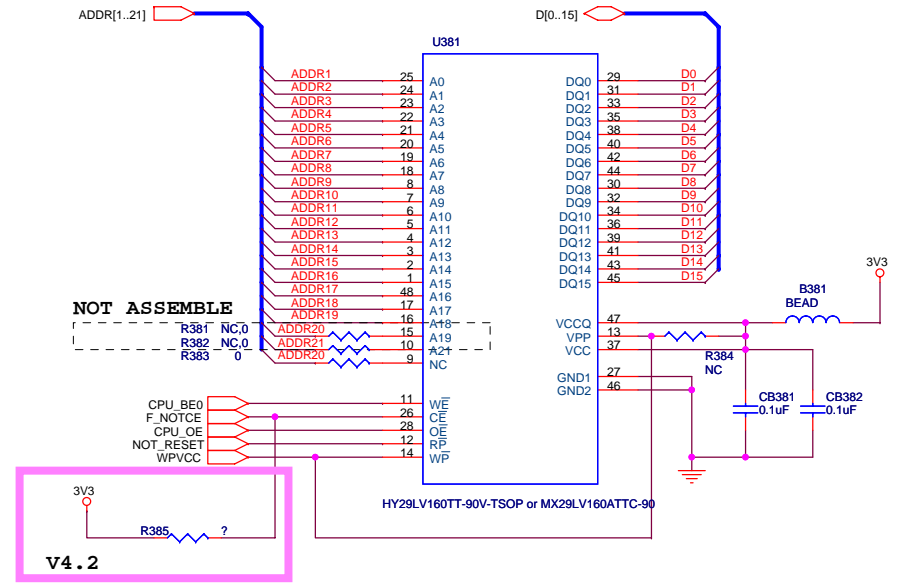

## SDRAM : XX371 ~

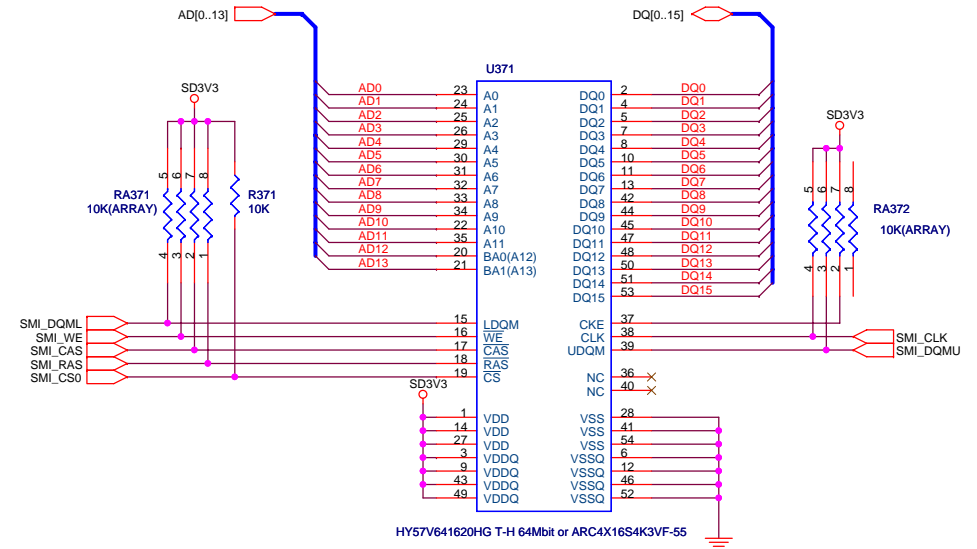
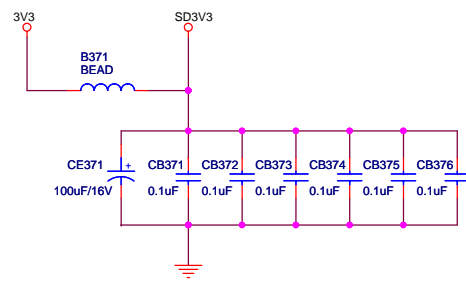

FILTER : XX701 ~

AK4702 : XX721 ~

SCART : XX751 ~

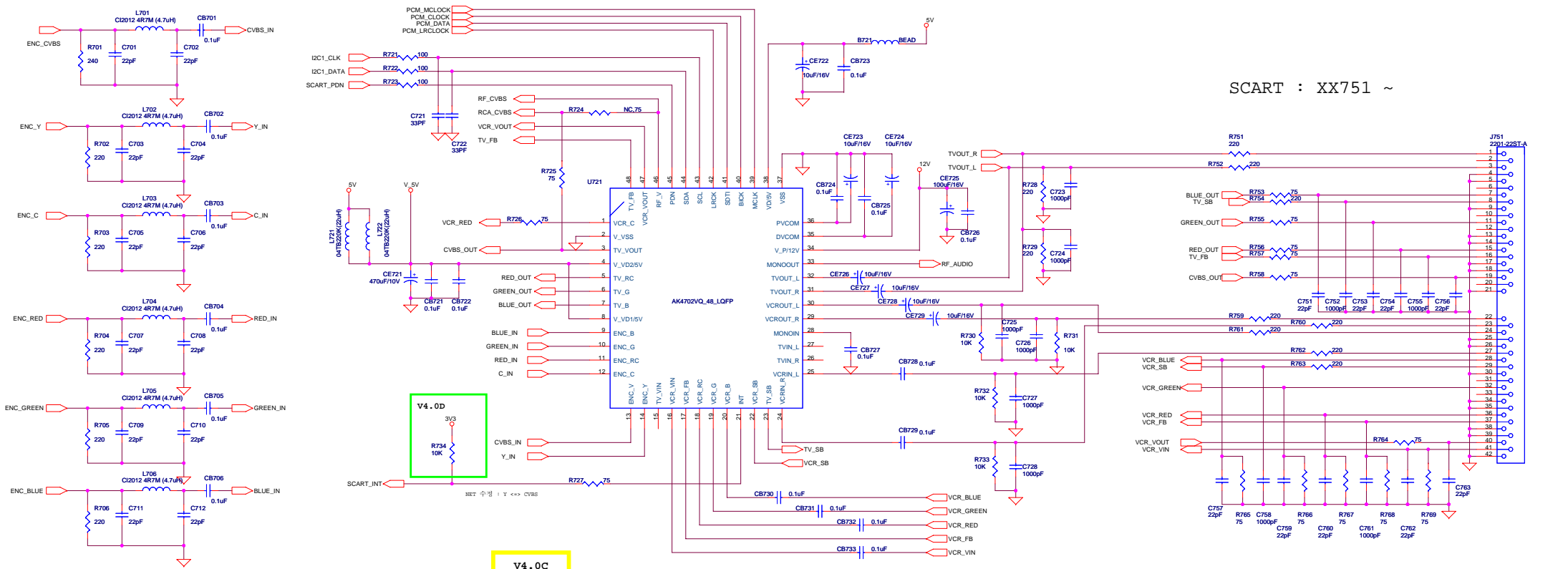

RCA : XX771 ~

RF\_MOD : XX801 ~

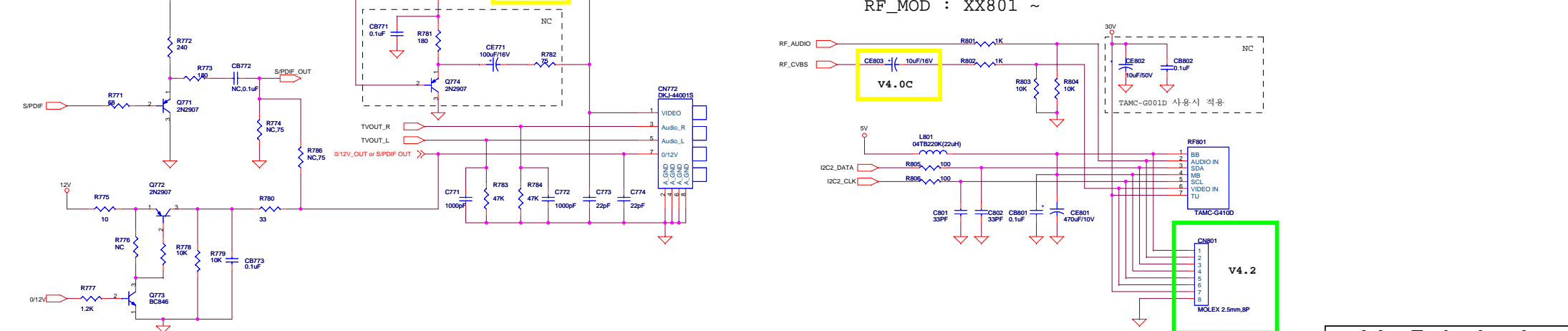

V4.0E

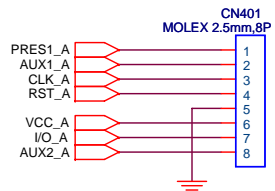
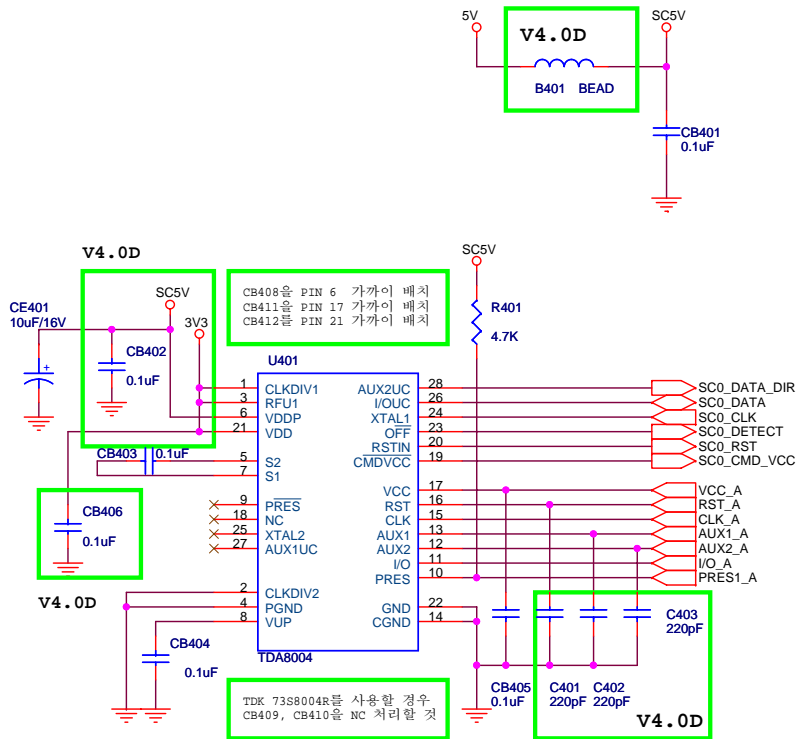

1-SMART\_SUB BOARD

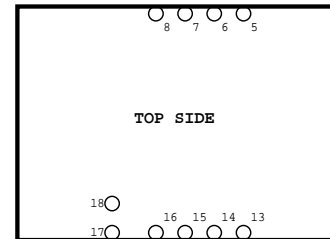
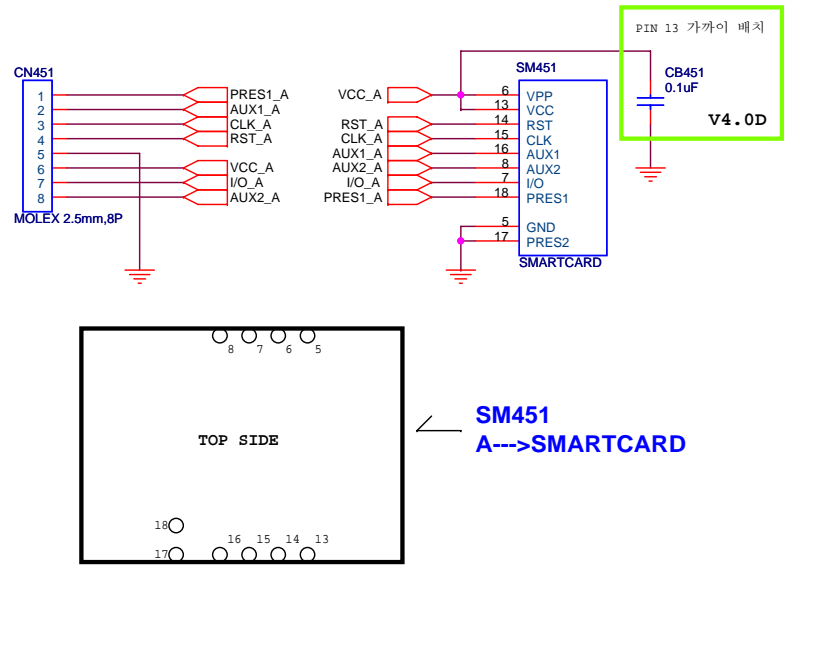

Arion Technology Inc.

AF-1900CI\_NEW

Size B	Document Number	Rev 4.2
06-SMART&SMART_SUB		
Date: Tuesday, July 27, 2004	Sheet 6 of 6	