

THIS DRAWING IS PROPERTY OF SCI DESIGN CENTER AND MUST NOT BE COPIED OR SHOWN OR GIVEN TO THIRD PERSON. VIOLATION OF THESE STIPULATIONS WILL BE SUBJECT TO LEGAL MEASURES ACCORDING TO EXISTING LAW.

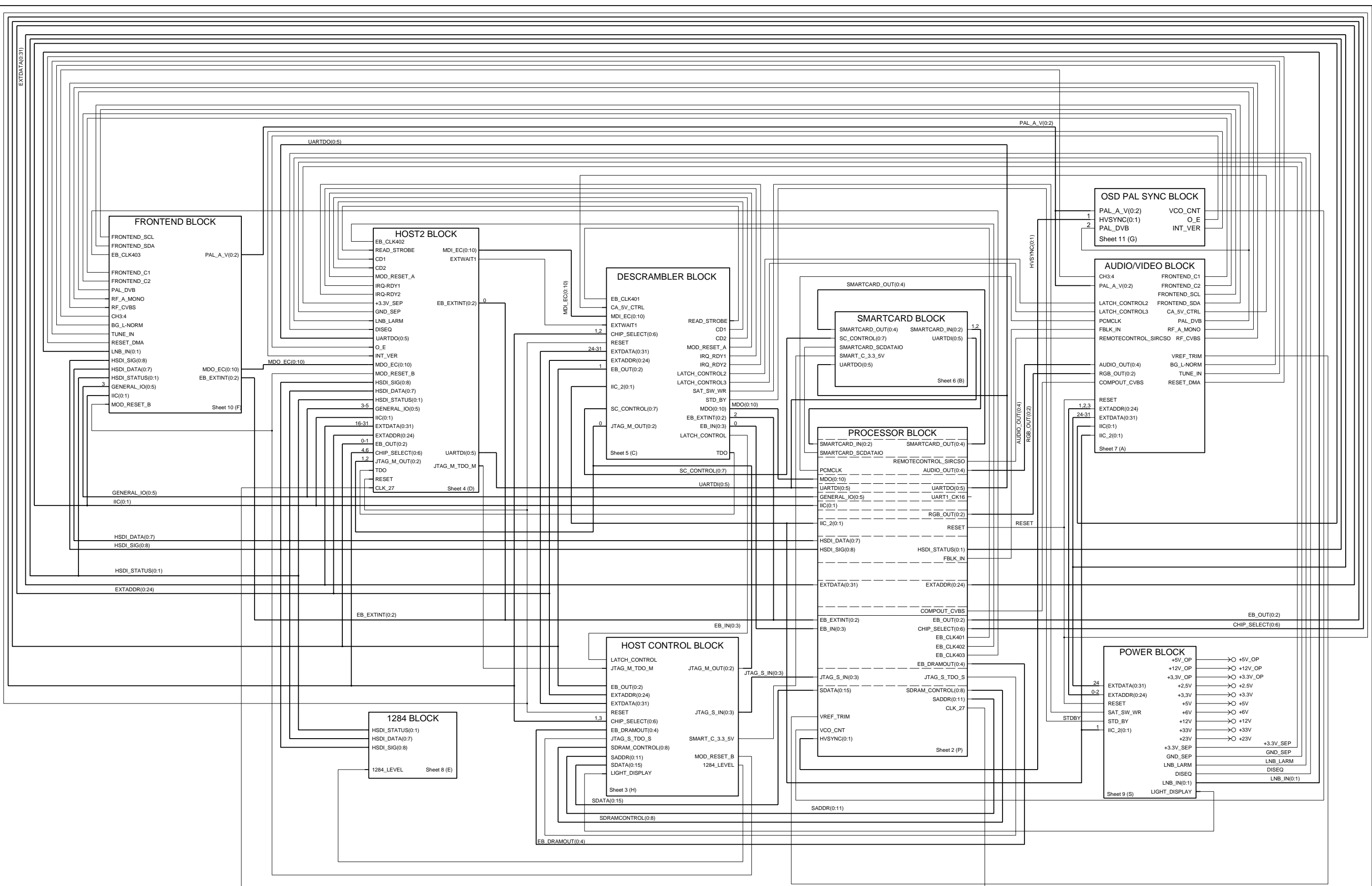

	ENGINEER	Palm Nils Erik	DRAWN BY	Sven-Ake Larsson	SHEET	1 of 11	BLOCK ID	SIZE
					DATE	2001-03-07	VARIANT	A3
Block overview <b>MAIN BOARD</b>					TIME	11:57:14	PCB	55 12212-01

THIS DRAWING IS PROPERTY OF SCI DESIGN CENTER AND MUST NOT BE COPIED OR SHOWN OR GIVEN TO THIRD PERSON. VIOLATION OF THESE STIPULATIONS WILL BE SUBJECT TO LEGAL MEASURES ACCORDING TO EXISTING LAW.

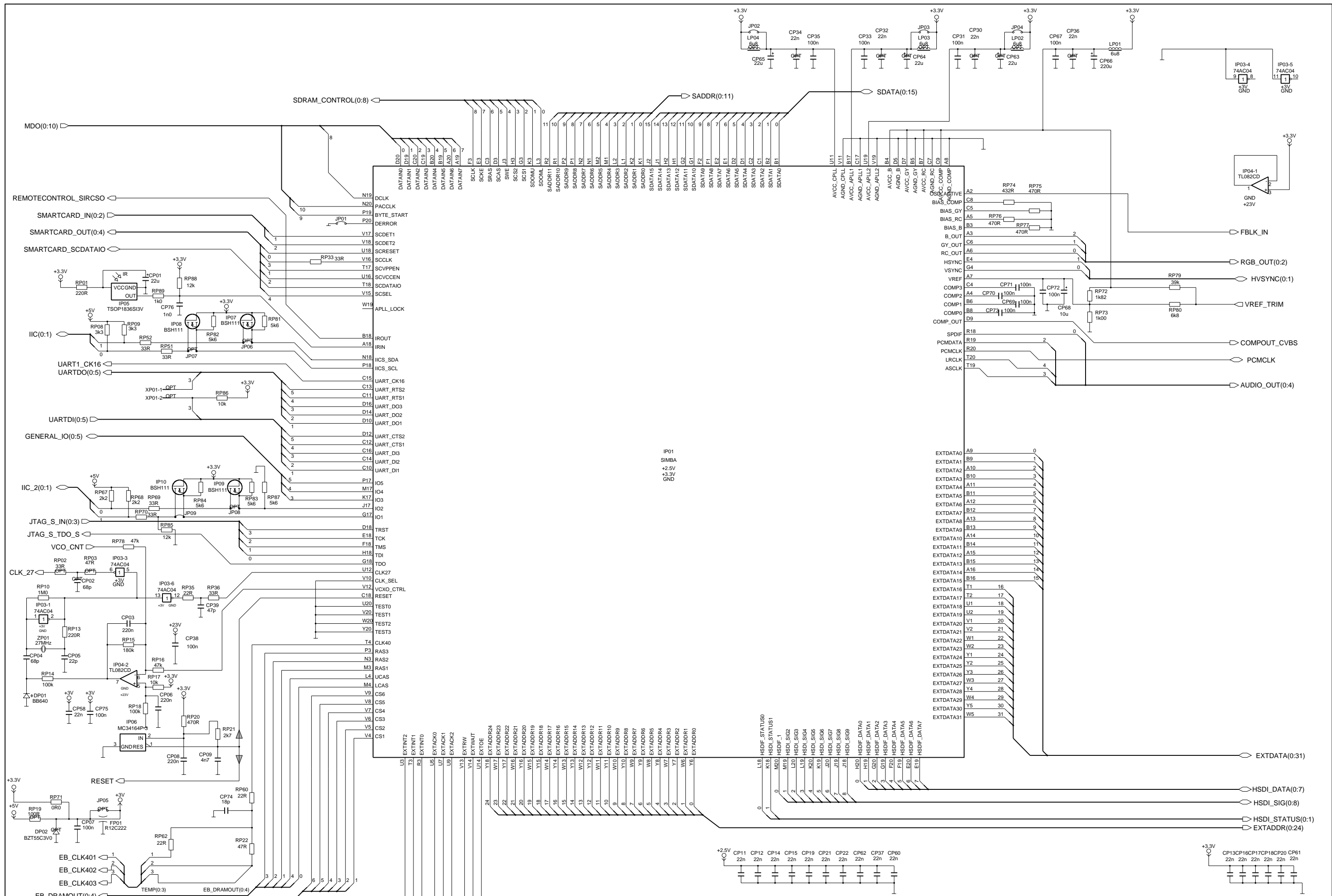

	ENGINEER	DRAWN BY	SHEET	BLOCK ID	SIZE
	Palm Nils Erik	Sven-Ake Larsson	2 of 11	P	A3
	Processor block			DATE	VARIANT
<b>MAIN BOARD</b>			TIME	PCB	
			11:57:14	55 12212-01	

THIS DRAWING IS PROPERTY OF SCI DESIGN CENTER AND MUST NOT BE COPIED OR SHOWN OR GIVEN TO THIRD PERSON. VIOLATION OF THESE STIPULATIONS WILL BE SUBJECT TO LEGAL MEASURES ACCORDING TO EXISTING LAW.

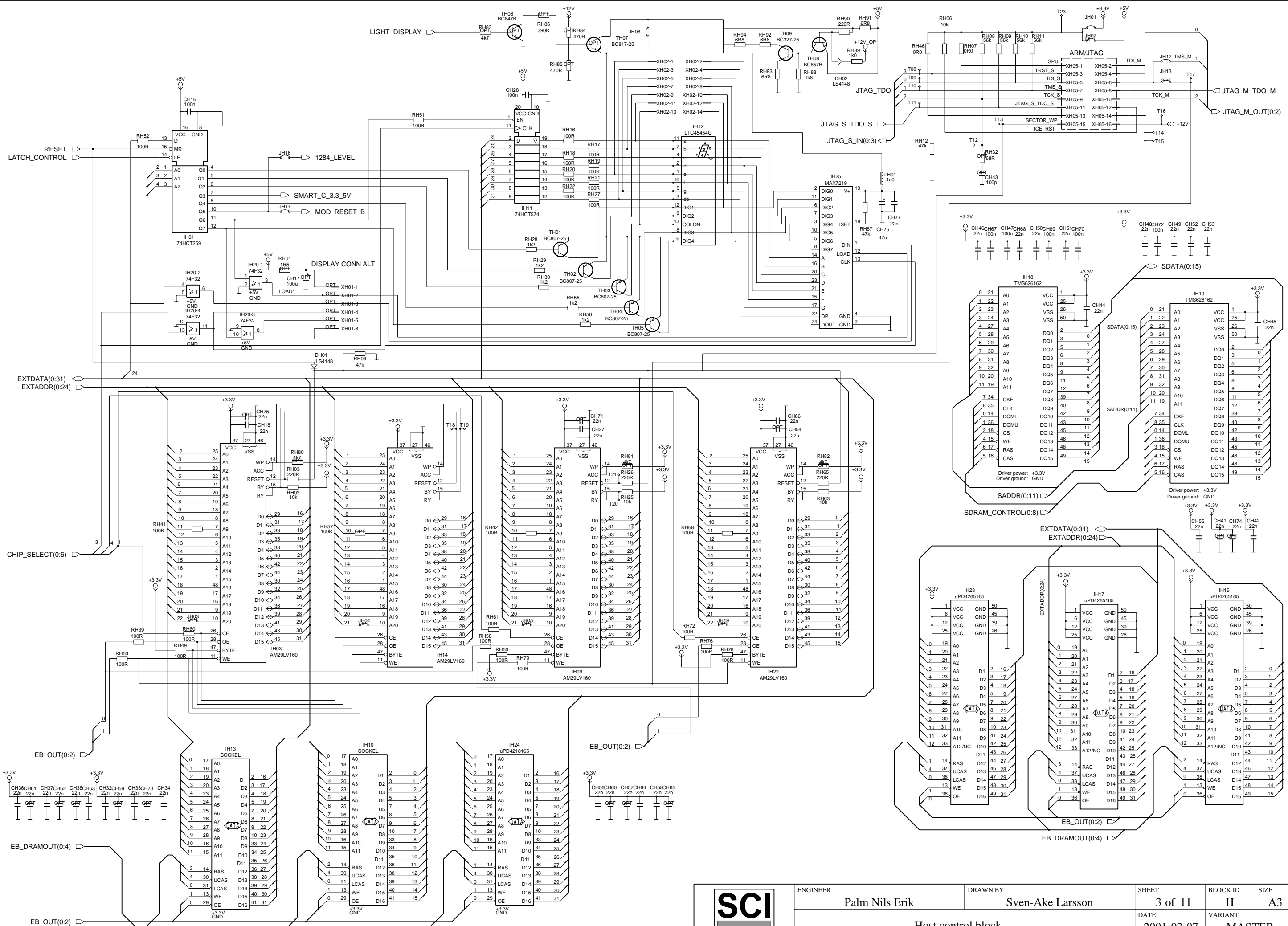

	ENGINEER	DRAWN BY	SHEET	BLOCK ID	SIZE
	Palm Nils Erik	Sven-Ake Larsson	3 of 11	H	A3
	Host control block			DATE	VARIANT
MAIN BOARD			TIME	PCB	
			2001-03-07	MASTER	
			11:57:14	55 12212-01	

THIS DRAWING IS PROPERTY OF SCI DESIGN CENTER AND MUST NOT BE COPIED OR SHOWN OR GIVEN TO THIRD PERSON. VIOLATION OF THESE STIPULATIONS WILL BE SUBJECT TO LEGAL MEASURES ACCORDING TO EXISTING LAW.

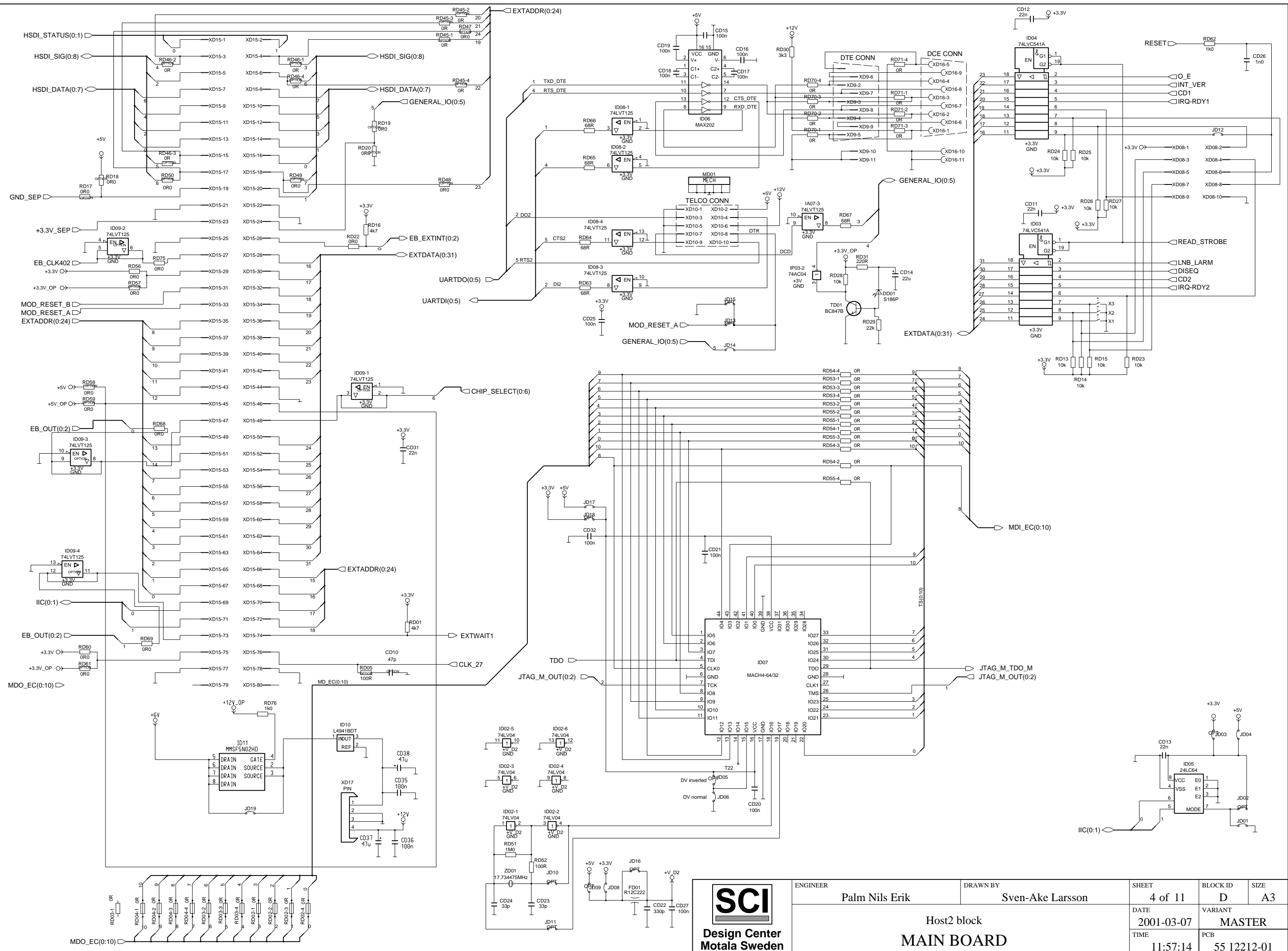

ENGINEER: Palm Nils Erik  
 DRAWN BY: Sven-Ake Larsson  
 Host2 block  
**MAIN BOARD**

SHEET	BLOCK ID	SIZE
4 of 11	D	A3
DATE	VARIANT	
2001-03-07	MASTER	
TIME	PCB	
11:57:14	55 12212-01	

THIS DRAWING IS PROPERTY OF SCI DESIGN CENTER AND MUST NOT BE COPIED OR SHOWN OR GIVEN TO THIRD PERSON. VIOLATION OF THESE STIPULATIONS WILL BE SUBJECT TO LEGAL MEASURES ACCORDING TO EXISTING LAW.

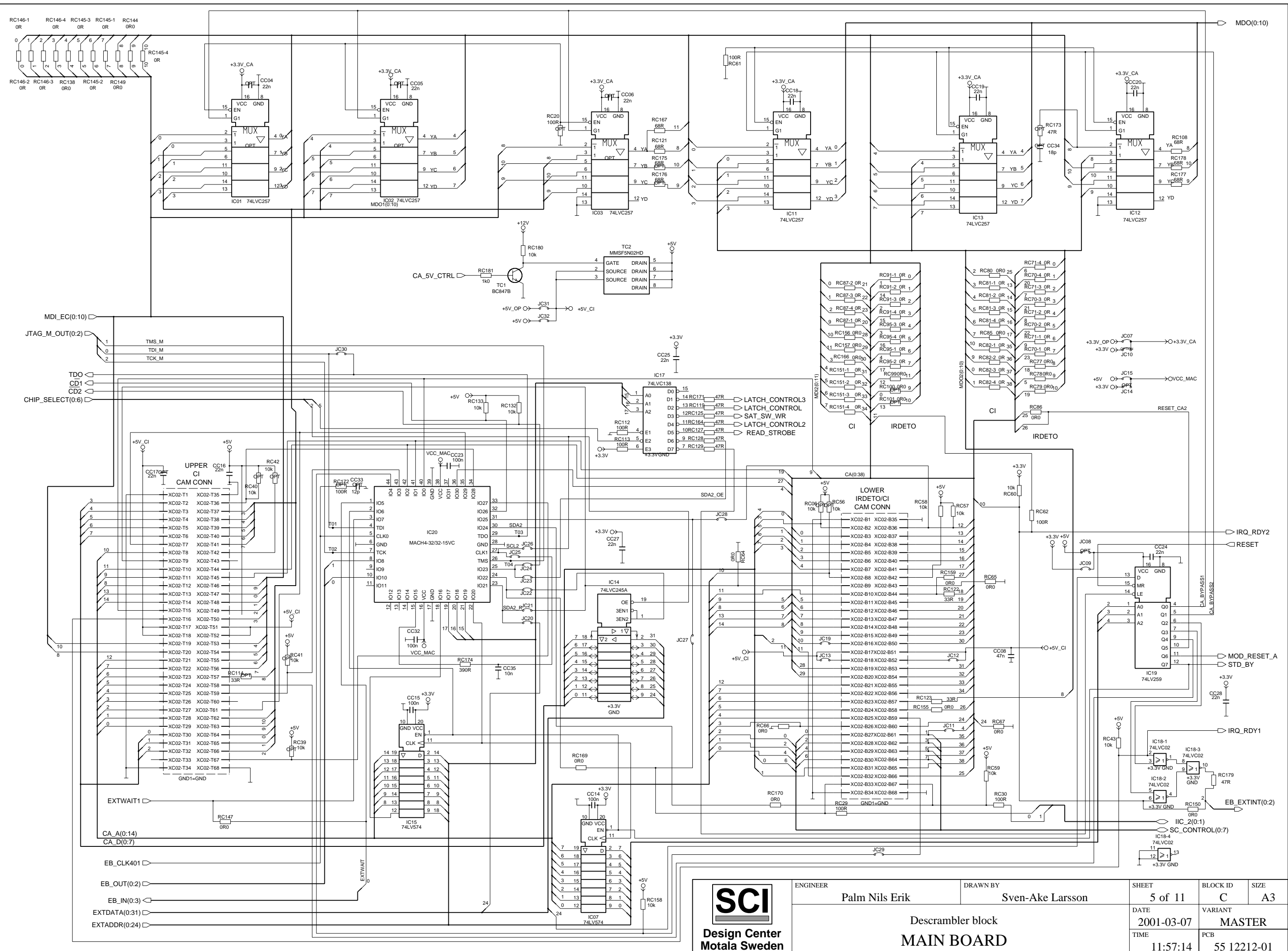

	ENGINEER	DRAWN BY	SHEET	BLOCK ID	SIZE
	Palm Nils Erik	Sven-Ake Larsson	5 of 11	C	A3
Descrambler block <b>MAIN BOARD</b>			DATE	VARIANT	
			2001-03-07	MASTER	
			TIME	PCB	
			11:57:14	55 12212-01	

THIS DRAWING IS PROPERTY OF SCI DESIGN CENTER AND MUST NOT BE COPIED OR SHOWN OR GIVEN TO THIRD PERSON. VIOLATION OF THESE STIPULATIONS WILL BE SUBJECT TO LEGAL MEASURES ACCORDING TO EXISTING LAW.

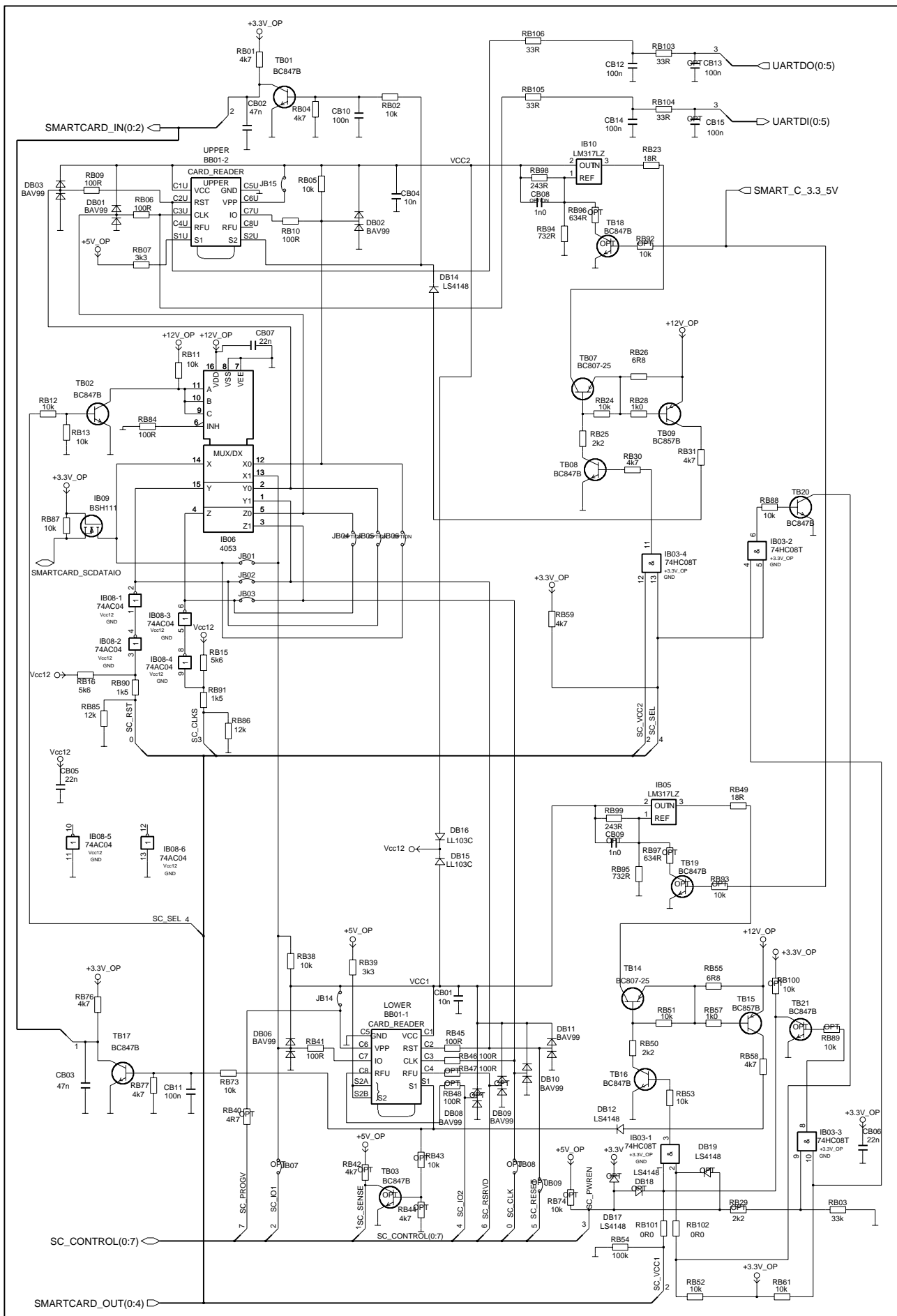

ENGINEER Palm Nils Erik  
 DRAWN BY Sven-Ake Larsson  
 Smartcard block  
**MAIN BOARD**

SHEET	BLOCK ID	SIZE
6 of 11	B	A4P
DATE	VARIANT	
2001-03-07	MASTER	
TIME	PCB	
11:57:14	55 12212-01	

THIS DRAWING IS PROPERTY OF SCI DESIGN CENTER AND MUST NOT BE COPIED OR SHOWN OR GIVEN TO THIRD PERSON. VIOLATION OF THESE STIPULATIONS WILL BE SUBJECT TO LEGAL MEASURES ACCORDING TO EXISTING LAW.

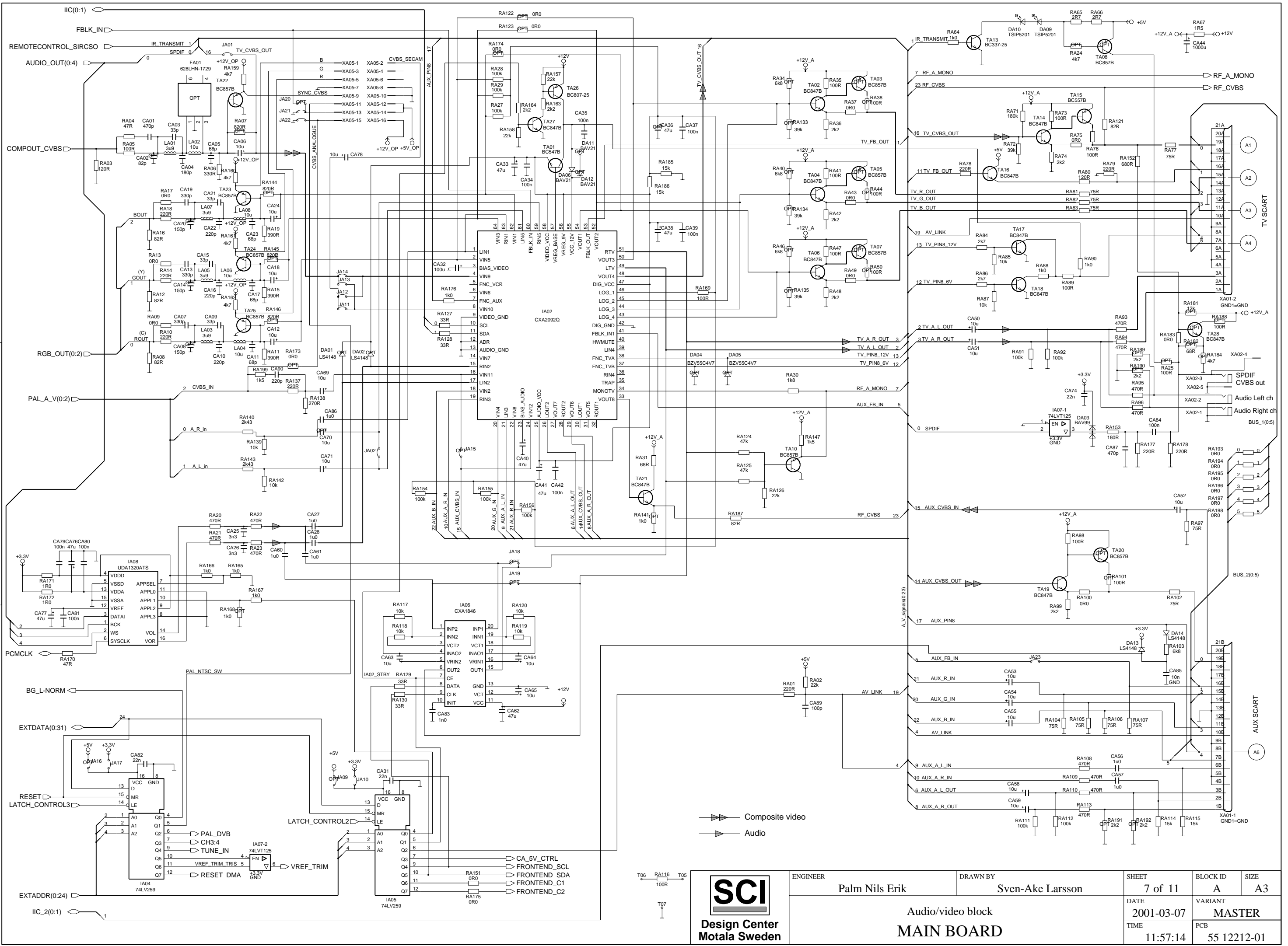

THIS DRAWING IS PROPERTY OF SCI DESIGN CENTER AND MUST NOT BE COPIED OR SHOWN OR GIVEN TO THIRD PERSON. VIOLATION OF THESE STIPULATIONS WILL BE SUBJECT TO LEGAL MEASURES ACCORDING TO EXISTING LAW.

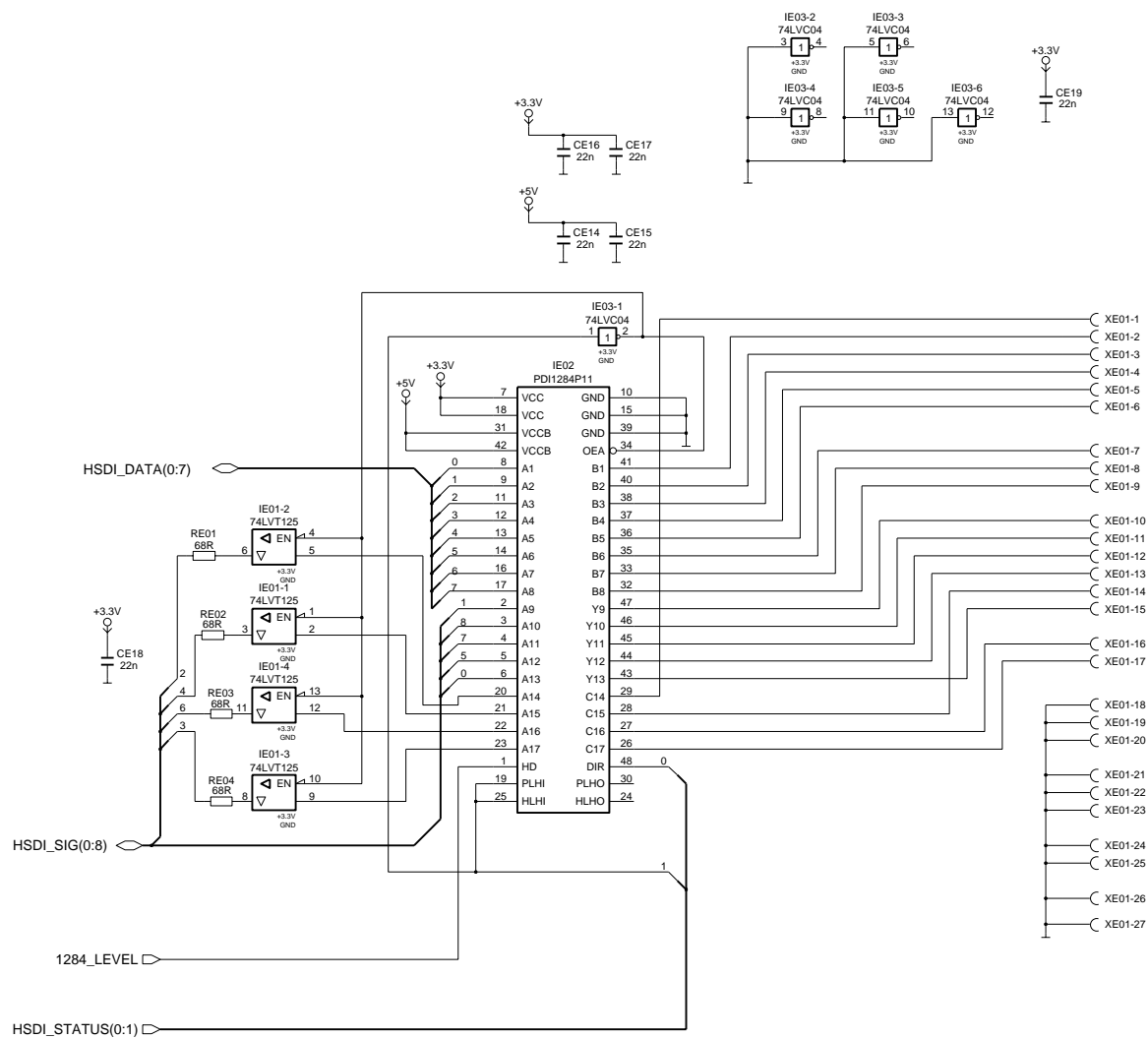

Design Center  
Motala Sweden

ENGINEER  
Palm Nils Erik

DRAWN BY  
Sven-Ake Larsson

1284 block  
MAIN BOARD

SHEET  
8 of 11

DATE  
2001-03-07

TIME  
11:57:14

BLOCK ID  
E

VARIANT  
MASTER

PCB  
55 12212-01

SIZE  
A4P



THIS DRAWING IS PROPERTY OF SCI DESIGN CENTER AND MUST NOT BE COPIED OR SHOWN OR GIVEN TO THIRD PERSON. VIOLATION OF THESE STIPULATIONS WILL BE SUBJECT TO LEGAL MEASURES ACCORDING TO EXISTING LAW.

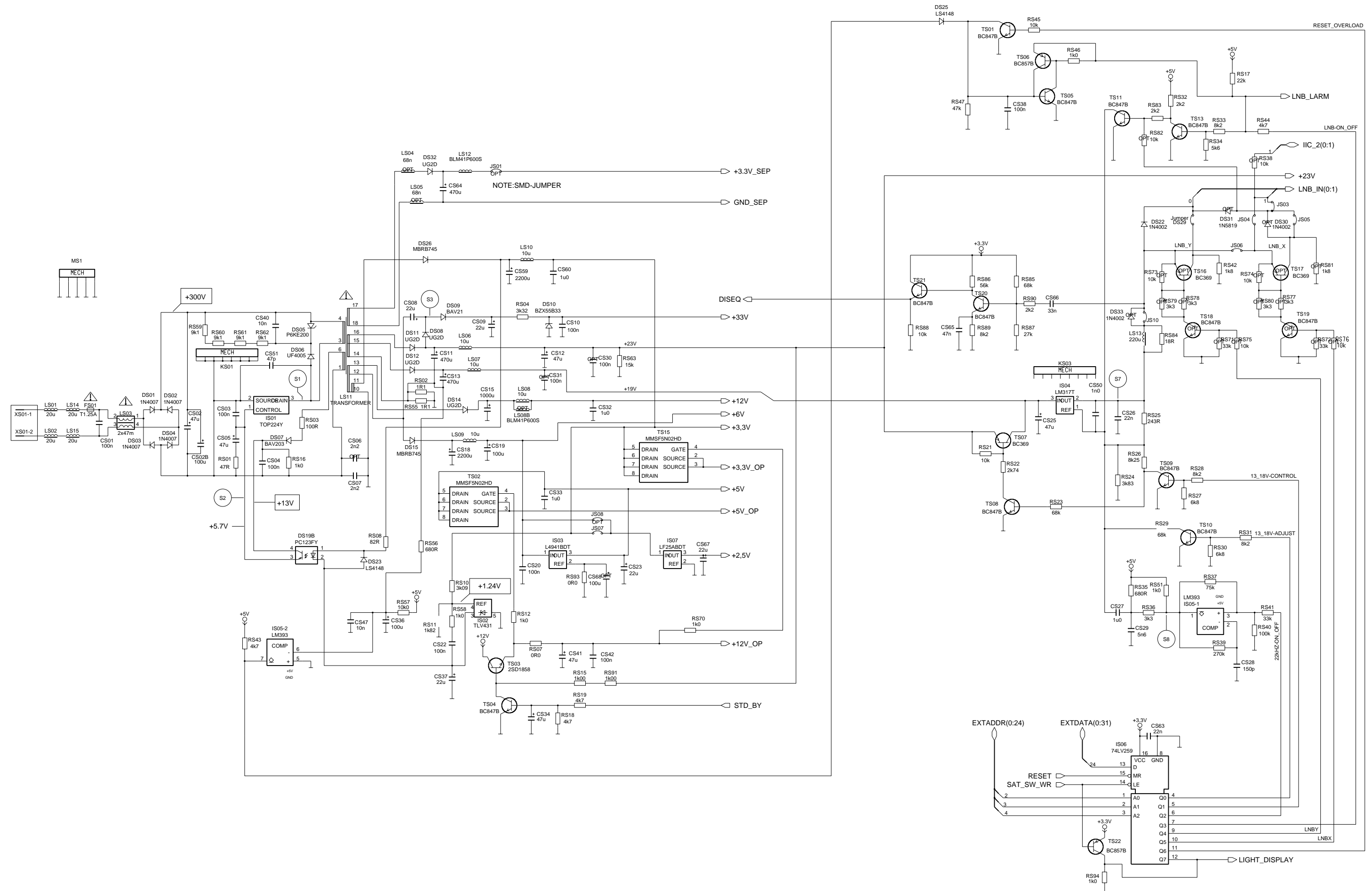

	ENGINEER	DRAWN BY	SHEET	BLOCK ID	SIZE
	Palm Nils Erik	Sven-Ake Larsson	9 of 11	S	A3
Power block <b>MAIN BOARD</b>			DATE	VARIANT	
			2001-03-07	MASTER	
			TIME	PCB	
			11:57:14	55 12212-01	

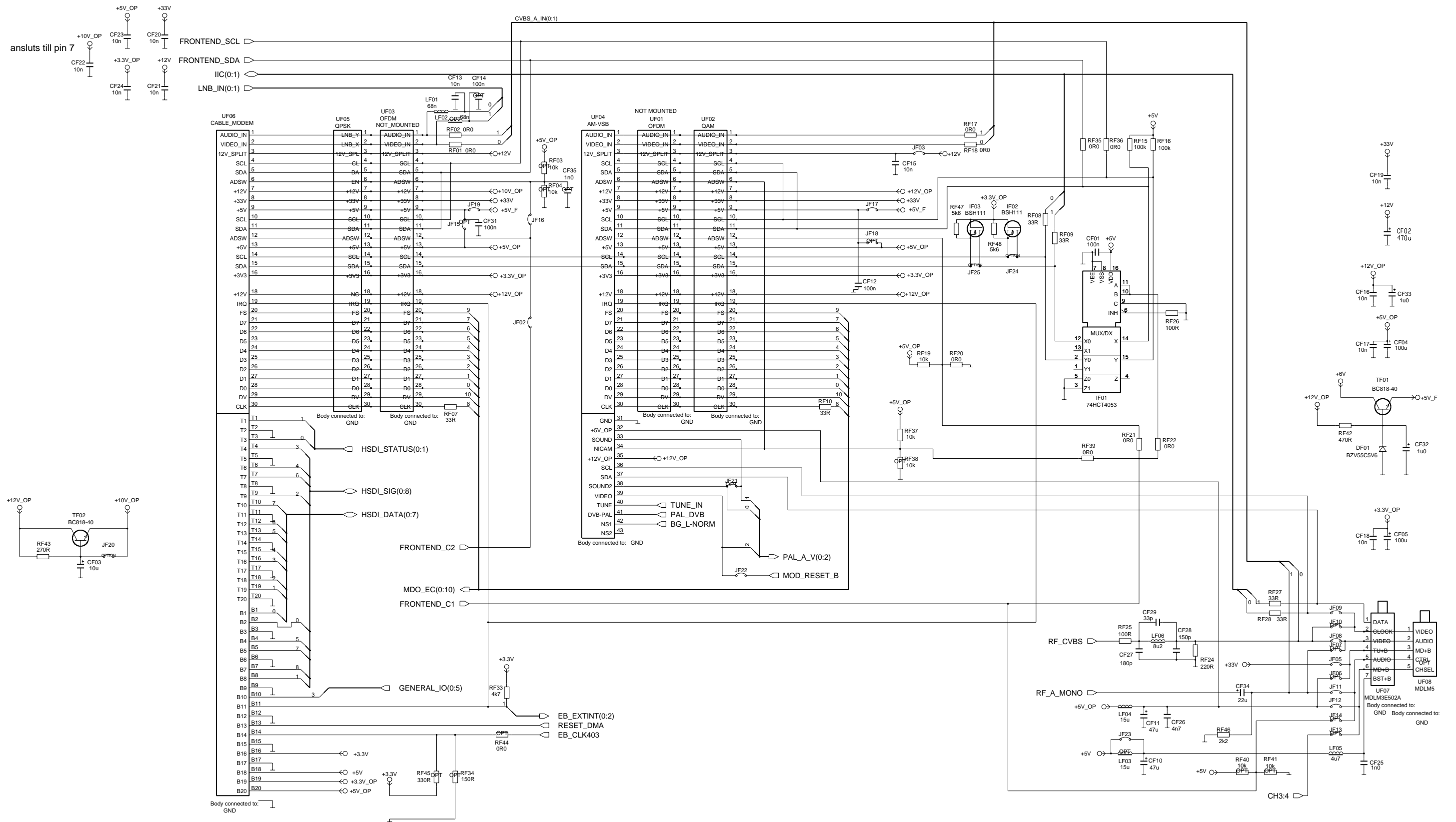

THIS DRAWING IS PROPERTY OF SCI DESIGN CENTER AND MUST NOT BE COPIED OR SHOWN OR GIVEN TO THIRD PERSON. VIOLATION OF THESE STIPULATIONS WILL BE SUBJECT TO LEGAL MEASURES ACCORDING TO EXISTING LAW.

	ENGINEER	Palm Nils Erik	DRAWN BY	Sven-Ake Larsson	SHEET	10 of 11	BLOCK ID	F	SIZE	A3
	Frontend block				DATE	2001-03-07	VARIANT	MASTER		
	MAIN BOARD				TIME	11:57:14	PCB	55 12212-01		

THIS DRAWING IS PROPERTY OF SCI DESIGN CENTER AND MUST NOT BE COPIED OR SHOWN OR GIVEN TO THIRD PERSON. VIOLATION OF THESE STIPULATIONS WILL BE SUBJECT TO LEGAL MEASURES ACCORDING TO EXISTING LAW.

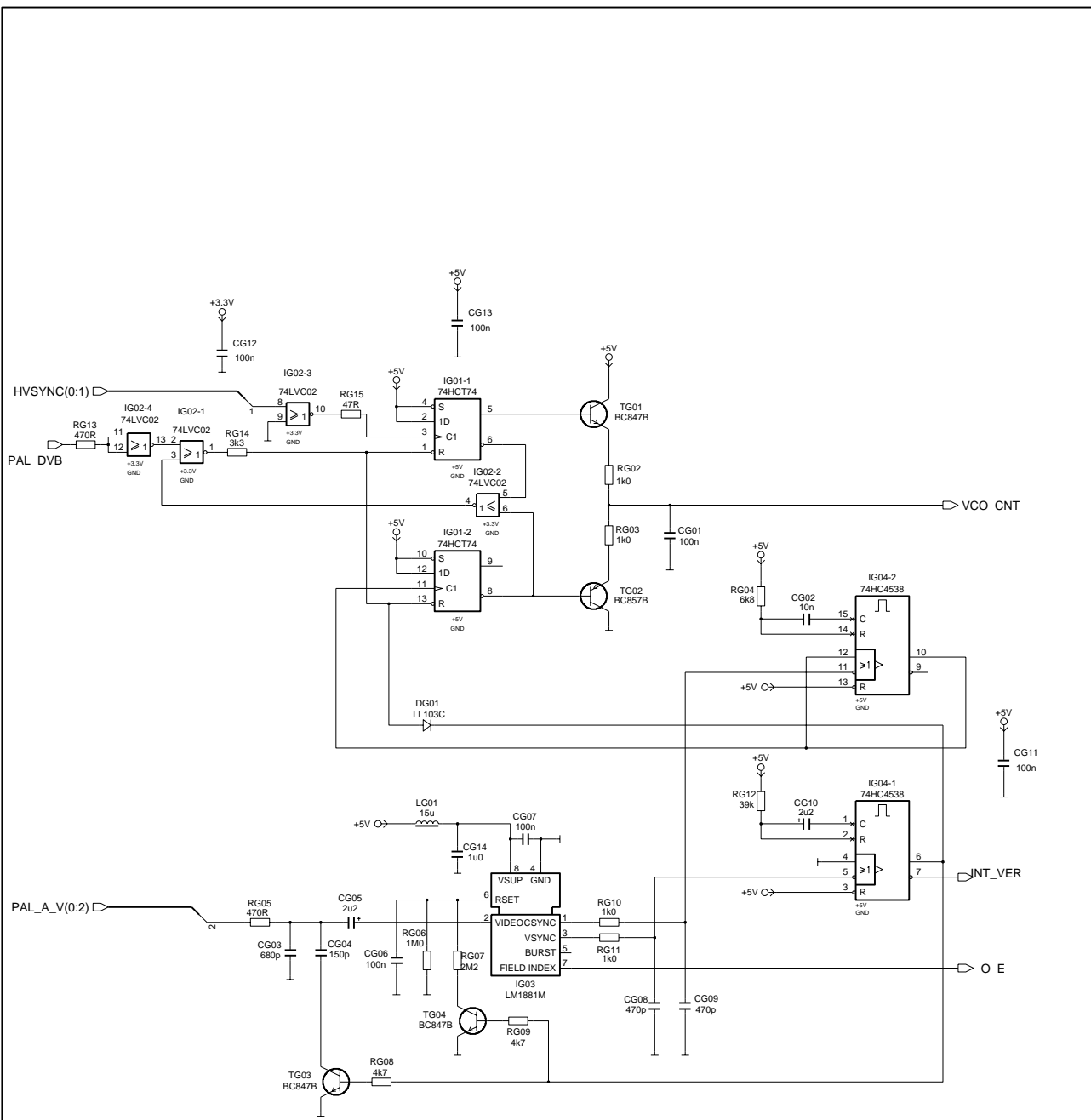

	ENGINEER	Palm Nils Erik	DRAWN BY	Sven-Ake Larsson	SHEET	11 of 11	BLOCK ID	G	SIZE	A4P
	OSD PAL sync block MAIN BOARD				DATE	2001-03-07	VARIANT		MASTER	
					TIME	11:57:14	PCB	55 12212-01		